

# AOC GAMING



Based on the characteristics of the OLED product, screen maintenance according to the requirements of the user instructions is recommended, so as to reduce the risk of generating image retention.

# USER MANUAL

## Q27G41ZDP

AOC GAMING MONITOR

Safety .....	1
National Conventions.....	1
Power .....	2
Installation .....	3
Cleaning.....	4
Other .....	5
Setup.....	6
Contents in Box.....	6
Set-up Stand & Base.....	7
Adjusting Viewing Angle.....	8
Connecting the Monitor .....	9
Wall Mounting.....	10
Adaptive-Sync function.....	11
NVIDIA G-SYNC Compatible function.....	12
HDR.....	13
Screen Maintenance.....	14
Adjusting.....	16
Hotkeys.....	16
OSD Setting.....	17
Game Setting.....	18
Picture .....	20
PIP/PBP .....	22
OLED Setting .....	23
Settings.....	25
Audio .....	26
OSD Setup.....	27
Information.....	28
LED Indicator.....	29
Troubleshoot.....	30
Specification .....	31
General Specification.....	31
Preset Display Modes.....	33
Pin Assignments.....	34
Plug and Play.....	35

# Safety

## National Conventions

The following subsections describe national conventions used in this document.

### Notes, Cautions, and Warnings

Throughout this guide, blocks of text may be accompanied by an icon and printed in bold type or in italic type. These blocks are notes, cautions, and warnings, and they are used as follows:



**NOTE:** A NOTE indicates important information that helps you make better use of your computer system.





**CAUTION:** A CAUTION indicates either potential damage to hardware or loss of data and tells you how to avoid the problem.



**WARNING:** A WARNING indicates the potential for bodily harm and tells you how to avoid the problem. Some warnings may appear in alternate formats and may be unaccompanied by an icon. In such cases, the specific presentation of the warning is mandated by regulatory authority.

## Power

 The monitor should be operated only from the type of power source indicated on the label. If you are not sure of the type of power supplied to your home, consult your dealer or local power company.

 The monitor is equipped with a three-pronged grounded plug, a plug with a third (grounding) pin. This plug will fit only into a grounded power outlet as a safety feature. If your outlet does not accommodate the three-wire plug, have an electrician install the correct outlet, or use an adapter to ground the appliance safely. Do not defeat the safety purpose of the grounded plug.

 Unplug the unit during a lightning storm or when it will not be used for long periods of time. This will protect the monitor from damage due to power surges.

 Do not overload power strips and extension cords. Overloading can result in fire or electric shock.

 To ensure satisfactory operation, use the monitor only with UL listed computers which have appropriate configured receptacles marked between 100-240V AC, Min. 5A.

 The wall socket shall be installed near the equipment and shall be easily accessible.

# Installation

**!** Do not place the monitor on an unstable cart, stand, tripod, bracket, or table. If the monitor falls, it can injure a person and cause serious damage to this product. Use only a cart, stand, tripod, bracket, or table recommended by the manufacturer or sold with this product. Follow the manufacturer's instructions when installing the product and use mounting accessories recommended by the manufacturer. A product and cart combination should be moved with care.

**!** Never push any object into the slot on the monitor cabinet. It could damage circuit parts causing a fire or electric shock. Never spill liquids on the monitor.

**!** Do not place the front of the product on the floor.

**!** If you mount the monitor on a wall or shelf, use a mounting kit approved by the manufacturer and follow the kit instructions.

**!** Leave some space around the monitor as shown below. Otherwise, air-circulation may be inadequate hence overheating may cause a fire or damage to the monitor.

**!** To avoid potential damage, for example the panel peeling from the bezel, ensure that the monitor does not tilt downward by more than -5 degrees. If the -5 degree downward tilt angle maximum is exceeded, the monitor damage will not be covered under warranty.

See below the recommended ventilation areas around the monitor when the monitor is installed on the wall or on the stand:

## Installed with stand



# Cleaning

⚠ Clean the cabinet regularly with a water-dampened, soft cloth.

⚠ When cleaning use a soft cotton or microfiber cloth. The cloth should be damp and almost dry, do not allow liquid into the case.



⚠ Please disconnect the power cord before cleaning the product.

## Other

 If the product is emitting a strange smell, sound or smoke, disconnect the power plug IMMEDIATELY and contact a Service Center.

 Make sure that the ventilating openings are not blocked by a table or curtain.

 Do not engage the OLED monitor in severe vibration or high impact conditions during operation.

 Do not knock or drop the monitor during operation or transportation.

 The power cords shall be safety approved. For Germany, it shall be H03VV-F, 3G, 0.75 mm<sup>2</sup>, or better. For other countries, the suitable types shall be used accordingly.

 Excessive sound pressure from earphones and headphones can cause hearing loss. Adjustment of the equalizer to maximum increases the earphones and headphones output voltage and therefore the sound pressure level.

 Low Blue Light: The display uses the low blue light panel. It complies with TÜV Rheinland Low Blue Light Hardware Solution certification under factory reset/default setting.

### Health:

- The monitor should be 50 ~ 70 cm (20 ~ 28 inches) away from your eyes.
- Looking at the screen for an extended period of time causes eye fatigue and may deteriorate your eyesight. Rest your eyes for 5 ~ 10 minutes for every 1 hour of product use.
- Reduce your eye strain by focusing on objects far way.
- Frequent blinking and eye exercise help keep your eyes from drying out.

 Flicker-free technology maintains a stable backlight with a DC dimmer that eliminates the primary cause of monitor flicker, making it easier on the eyes.

 Based on the characteristics of the OLED products, it is not recommended to continuously use this product for more than 24 hours. This product uses many technologies to eliminate possible image retention. For details, refer to instructions on "Screen Maintenance."

# Setup

## Contents in Box

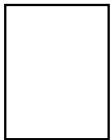
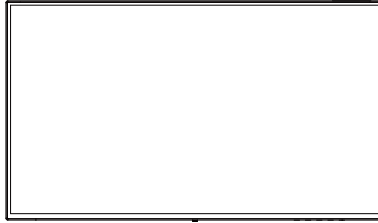

Quick Start Guide



Warranty card



Stand

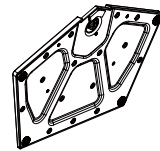

Base



Power Cable



HDMI Cable



DisplayPort Cable

\* Not all signal cables will be provided for all countries and regions. Please check with the local dealer or AOC branch office for confirmation.

# Set-up Stand & Base

Please setup or remove the base following the steps as below.

## Setup:

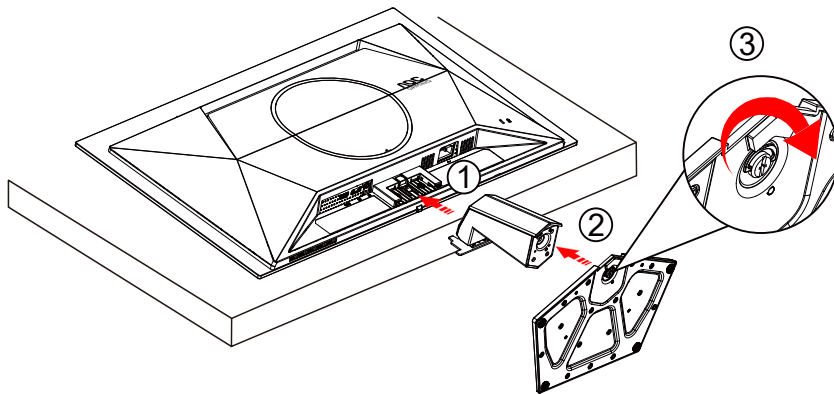

## Remove:

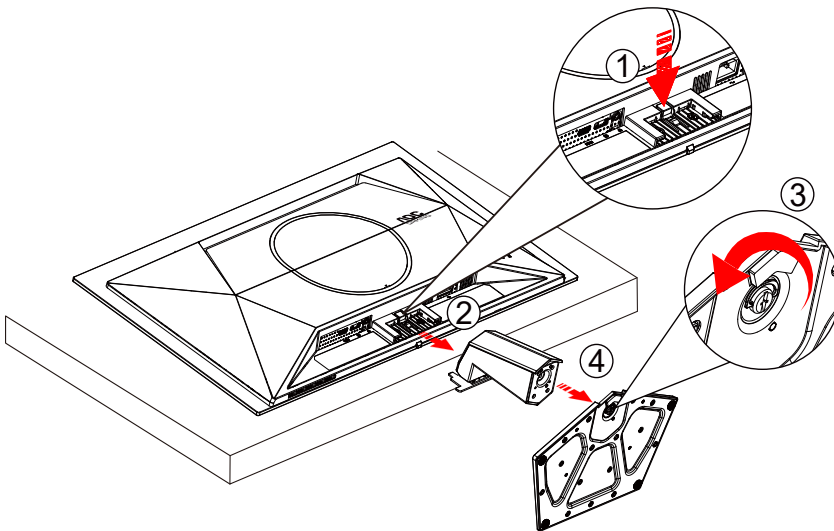

 **NOTE:** Display design may differ from those illustrated.

Specification for base screw: M6\*20 mm (effective thread 5.5 mm)

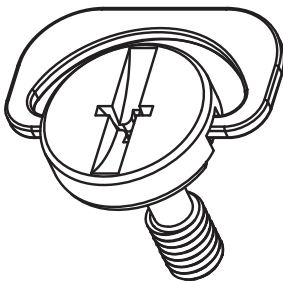

## Adjusting Viewing Angle

To achieve the best viewing experience, it is recommended that the user can make sure they are able to look at their whole face on the screen, then adjust the monitor's angle based on personal preference. Hold the stand so you will not topple the monitor when you change the monitor's angle. You are able to adjust the monitor as below:

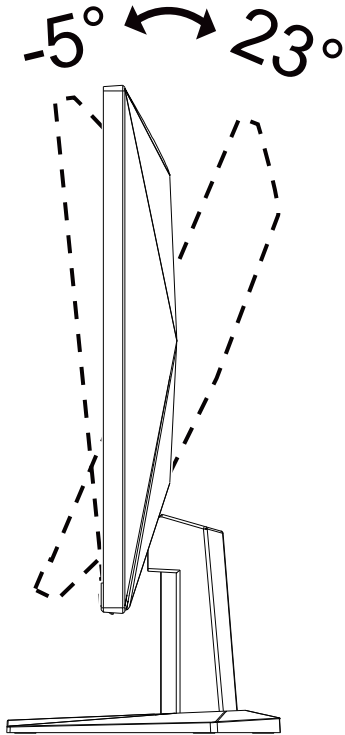

### NOTE:

Do not touch the OLED screen when you change the angle. Touching the OLED screen may cause damage.

### Warning

- To avoid potential screen damage, such as panel peeling, ensure that the monitor does not tilt downward by more than -5 degrees.
- Do not press the screen while adjusting the angle of the monitor. Grasp only the bezel.

# Connecting the Monitor

Cable Connections In Back of Monitor and Computer:

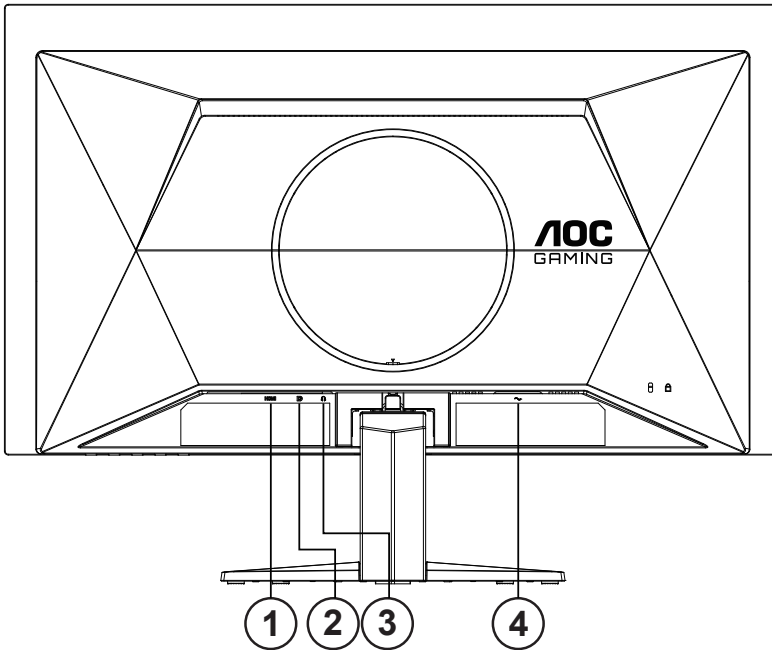

1. HDMI
2. DisplayPort
3. Earphone
4. Power

## Connect to PC

1. Connect the power cord to the back of the display firmly.
2. Turn off your computer and unplug its power cable.
3. Connect the display signal cable to the video connector on the back of your computer.
4. Plug the power cord of your computer and your display into a nearby outlet.
5. Turn on your computer and display.

If your monitor displays an image, installation is complete. If it does not display an image, please refer to Troubleshoot.

To protect equipment, always turn off the PC and OLED monitor before connecting.

# Wall Mounting

Preparing to Install An Optional Wall Mounting Arm.

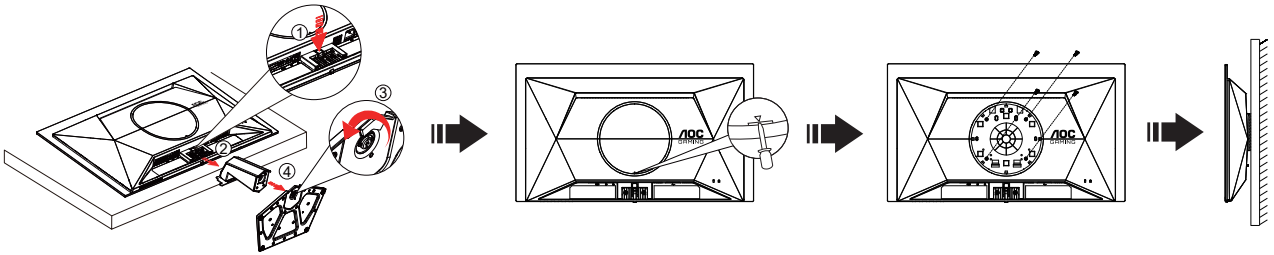

This monitor can be attached to a wall mounting arm you purchase separately. Disconnect power before this procedure. Follow these steps:

1. Remove the base.
2. Follow the manufacturer's instructions to assemble the wall mounting arm.
3. Place the wall mounting arm onto the back of the monitor. Line up the holes of the arm with the holes in the back of the monitor.
4. Insert the 4 screws into the holes and tighten.
5. Reconnect the cables. Refer to the user's manual that came with the optional wall mounting arm for instructions on attaching it to the wall.

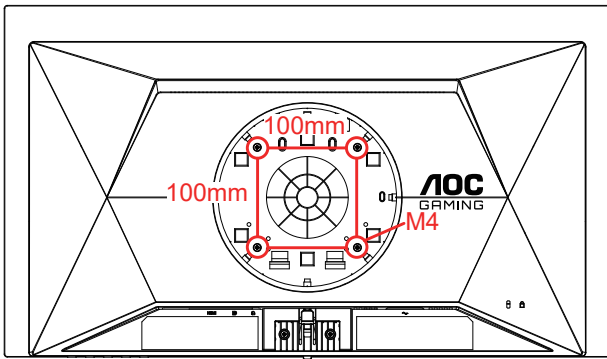

Specification of wall hanger screws: M4\*(10+x)mm, ( X=Thickness of Wall mount bracket )

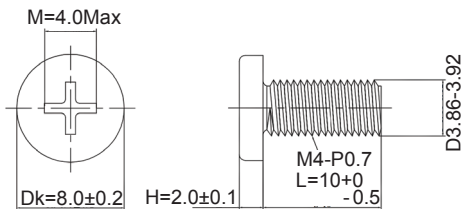

**Note:** VESA mounting screw holes are not available for all models, please check with the dealer or official department of AOC. Always contact manufacturer for wall-mount installation.

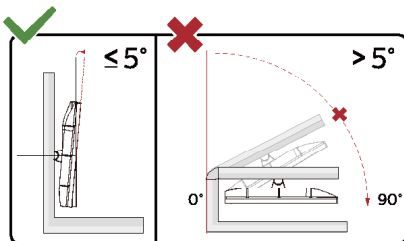

\* Display design may differ from those illustrated.

## ⚠WARNING:

1. To avoid potential screen damage, such as panel peeling, ensure that the monitor does not tilt downward by more than -5 degrees.
2. Do not press the screen while adjusting the angle of the monitor. Grasp only the bezel.

# Adaptive-Sync function

1. Adaptive-Sync function works with DisplayPort/HDMI.
2. Compatible Graphics Card: Recommended list is as below, also could be checked by visiting [www.AMD.com](http://www.AMD.com)

## Graphics Cards

- Radeon™ RX Vega series
- Radeon™ RX 500 series
- Radeon™ RX 400 series
- Radeon™ R9/R7 300 series (R9 370/X, R7 370/X, R7 265 except)
- Radeon™ Pro Duo (2016)
- Radeon™ R9 Nano series
- Radeon™ R9 Fury series
- Radeon™ R9/R7 200 series (R9 270/X, R9 280/X except)

## Processors

- AMD Ryzen™ 7 2700U
- AMD Ryzen™ 5 2500U
- AMD Ryzen™ 5 2400G
- AMD Ryzen™ 3 2300U
- AMD Ryzen™ 3 2200G
- AMD PRO A12-9800
- AMD PRO A12-9800E
- AMD PRO A10-9700
- AMD PRO A10-9700E
- AMD PRO A8-9600
- AMD PRO A6-9500
- AMD PRO A6-9500E
- AMD PRO A12-8870
- AMD PRO A12-8870E
- AMD PRO A10-8770
- AMD PRO A10-8770E
- AMD PRO A10-8750B
- AMD PRO A8-8650B
- AMD PRO A6-8570
- AMD PRO A6-8570E
- AMD PRO A4-8350B
- AMD A10-7890K
- AMD A10-7870K
- AMD A10-7850K
- AMD A10-7800
- AMD A10-7700K
- AMD A8-7670K
- AMD A8-7650K
- AMD A8-7600
- AMD A6-7400K

## NVIDIA G-SYNC Compatible function

1. 本产品支持 NVIDIA G-SYNC Compatible 功能。NVIDIA G-SYNC Compatible 功能在 DisplayPort 接口下可以运行。
2. To enjoy the perfect gaming experience with G-SYNC, you need to purchase a Separate NVIDIA GPU card that supports G-SYNC.

G-sync system requirements:

要求类别: NVIDIA G-SYNC Compatible 显示器 (兼容模式)

显卡: NVIDIA Pascal 架构或更高 (如 GTX 10 系列、RTX 系列)

显示器: 通过 NVIDIA 验证的、支持可变刷新率 (VRR) 的显示器

操作系统: Windows 10 或更高版本

连接线缆: 使用 DisplayPort 接口

For more information about NVIDIA G-Sync, please visit: <https://www.nvidia.com/en-us/support>

# HDR

It is compatible with input signals in HDR10 format.

The display may automatically activate the HDR function if the player and content are compatible. Please contact the device manufacturer and the content provider for information on the compatibility of your device and content. Please select "OFF" for the HDR function when you have no need for automatic activation function.

## Note:

1. No special setting is needed for the DisplayPort/HDMI interface in WIN10 versions lower (older) than V1703.
2. Only the HDMI interface is available and the DisplayPort interface cannot function in WIN10 version V1703.
3. 3840x2160@50Hz/60Hz only suggest for Blu-ray Player, Xbox and PlayStation.
4. Display Setting:
  - a. The display resolution is set to 2560x1440, and HDR is preset to ON.
  - a. After entering an application, the best HDR effect can be achieved when the resolution is changed to 2560x1440 (if available).

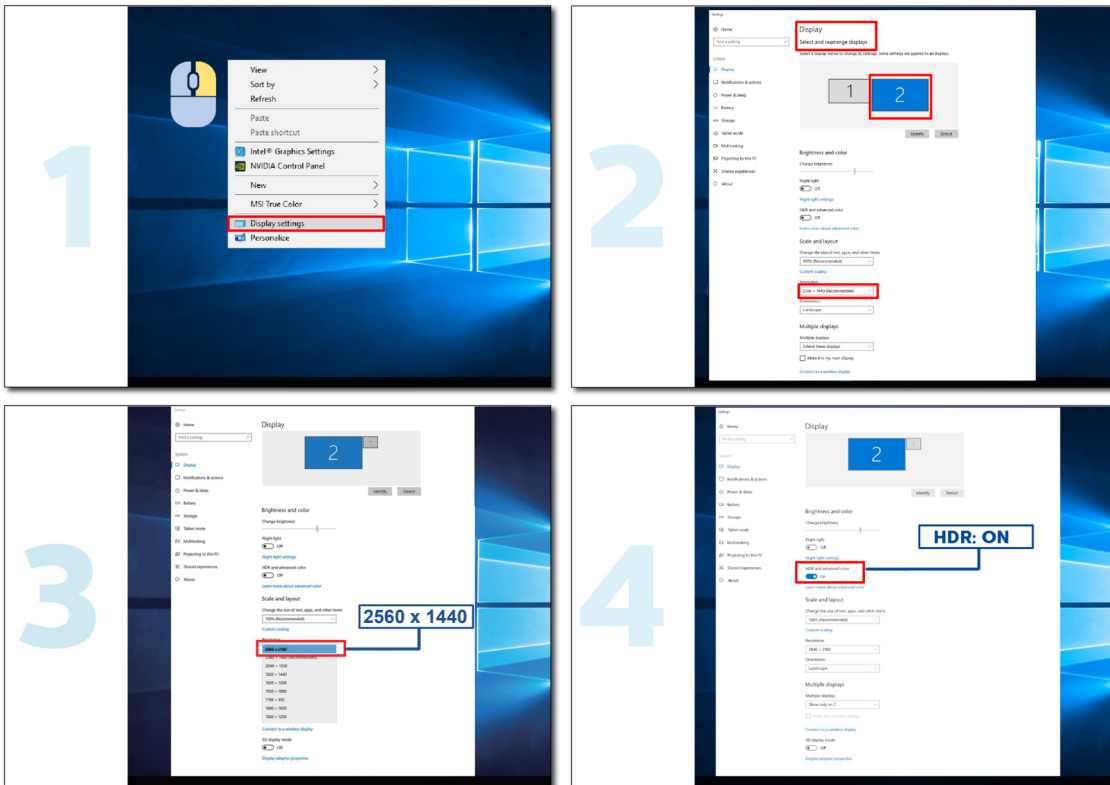

# Screen Maintenance

Based on the characteristics of the OLED product, screen maintenance should be carried out according to the following requirements, so as to reduce the risk of generating image retention.

The warranty does not cover any damage resulting from non-compliance to the following instructions.

- **Displaying a still image should be avoided as much as possible.**

A still image refers to an image which remains on the screen for a long time.

A still image may result in permanent damage to the OLED screen, image residue appears, which is the feature of OLED screen.

The following suggestions on use should be abided by:

1. Do not display any still image in full screen or part of the screen for a long time, because this will lead to screen image residue. To avoid this problem, please reduce the brightness and contrast of the screen appropriately when displaying still image.
2. Different traces will remain on the left and right sides of the screen and at the margins of the image when you watch non-full-screen content for a long time. Therefore, do not use such mode for long periods.
3. Whenever possible, watch a video in full screen, rather than in a small window on the screen (such as a video on an Internet browser page).
4. Do not put labels or stickers on the screen to reduce the possibility of screen damage or image residue.

- **It is not recommended to continuously use this product for more than 24 hours.**

This product uses many technologies to eliminate possible image retention. It is highly recommended that you use the preset values and keep the functions “On” to avoid image residue on the OLED screen and maintain the best use of the OLED display.

- **LEA (Logo Extraction Algorithm, Prevention of local image retention)**

To reduce the risk of generating image retention, it is recommended to enable the LEA function.

After this function is enabled, the screen will be automatically narrowed to fix the brightness of the display area, so as to reduce possible image retention.

This setting is “On” by default. You can set in the OSD menu.

- **Pixel Orbiting**

To reduce the risk of generating image retention, it is recommended to enable the Orbit function.

After this function is turned on, image pixels circularly move as a whole once a second in a trajectory shaped like a Chinese character “ 日 ”. The movement amplitude is based on the settings. The moved character may be side cut. When “Strongest” is selected, image retention is most unlikely generated, but possible side cut may be most notable. When “Off” is selected, the image will go back to the optimal position.

This setting is “On” (Strongest) by default. You can set in the OSD menu.

- **Pixel Refresh**

Based on the characteristics of the OLED panel, image retention tends to appear when a still image divided by different colors or brightness is displayed for a long time.

To eliminate the image retention which may have been generated, it is recommended to regularly or irregularly re-run the “Pixel Refresh” function, so as to obtain an ideal image display effect.

This function can be run by any of the following options:

- 1). In the OSD menu, manually enable “Pixel Refresh”, and select “Yes” according to the menu prompt.

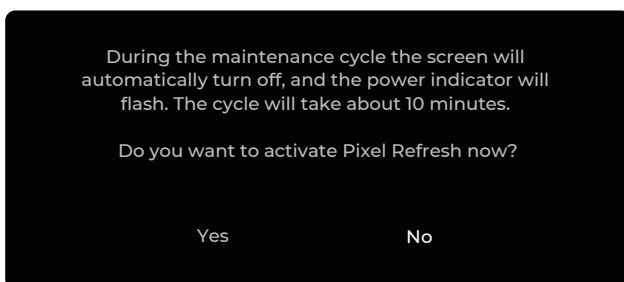

2). The monitor automatically pop up a prompt menu to remind the user to run "Pixel Refresh" every 24 hours. It is recommended to select "Yes".

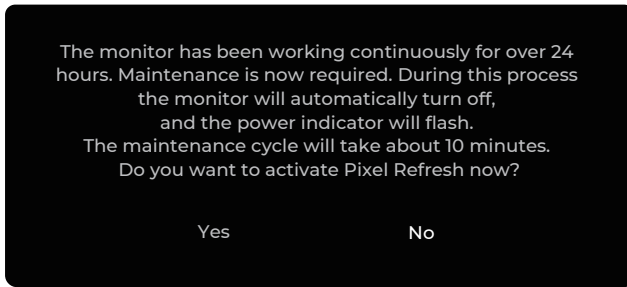

If "No" is selected or no selection is made, the alert will be given once an hour until the user selects "Yes". The prompt menu automatically closes after about 10 seconds.

The automatic prompt function of "Pixel Refresh" is "On" by default and can be set in the OSD menu. If it is set to "Off", the automatic prompt menu of "Pixel Refresh" will no longer appear.

Special note: Failure to perform "Pixel Refresh" at the recommended time will increase the risk of image residual on the screen. This may affect your warranty coverage. Please proceed cautiously.

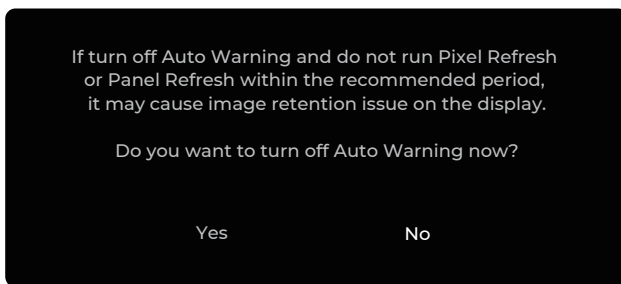

3). After every cumulative 4 hours of operation, if the monitor is either turned off via its button or enters standby mode, it will automatically perform Screen Compensation and Correction and Pixel Refresh 15 minutes later.

The monitor will automatically run Screen Compensation and Correction first, and then run Pixel Refresh. Please keep the power on and avoid pressing any buttons during the Screen Compensation and Correction process. The power indicator will flash white (white for 3 seconds/off for 3 seconds), and this process will take approximately 30 seconds. Subsequently, the monitor will run the Pixel Refresh function.

The entire Pixel Refresh process takes approximately 10 minutes. Please keep the power on and avoid pressing any buttons. The power indicator will flash white (on a second/off a second). The power indicator will turn orange or turn off at the end, indicating that the monitor has entered standby or power-off state (maintaining the pre-operation status).

If the user presses the power button during the process, the operation will be interrupted, and the monitor will restore the image. Please note that this restoration may take approximately 5 seconds. In the OSD menu "Information", you can view the number of times the Pixel Refresh function has been run and the time when the screen lights up after the last Pixel Refresh.

#### • Screen Saver

To reduce the risk of image retention, it is recommended to turn on the screen saver. When still images are displayed for long periods of time, the brightness of the screen is automatically reduced significantly to reduce possible image retention. When an image change is detected, the screen will revert to its previous display brightness.

This setting is "On" by default. You can set in the OSD menu.

# Adjusting

## Hotkeys

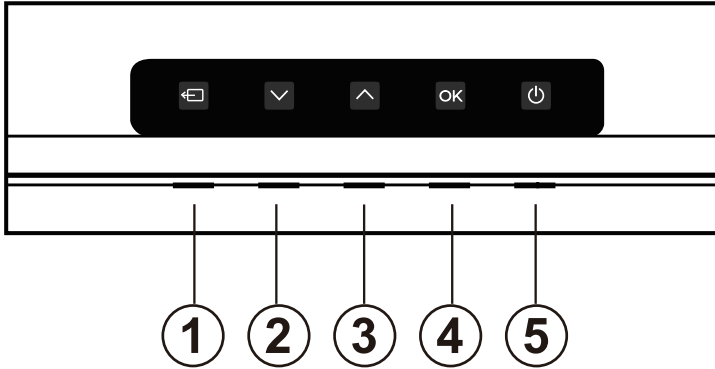

注意：按任意按键，显示 OSD 按键图标。

1	Source/ Exit
2	User Key (Gaming Mode)/ Decrease
3	Dial Point/ Increase
4	Menu/ Select
5	Power

### Power

当显示器关闭时，短按此键打开显示器电源。

当显示 OSD 按键图标时，短按此键关闭显示器电源；当未显示 OSD 按键图标时，长按此键约 3 秒关闭显示器电源。

### Menu/Select

激活 OSD 菜单或功能调整确认。

### Dial Point/ Increase

当 OSD 菜单处于关闭状态时，重复按“^”键以打开或关闭游戏准星。显示器开/关后，游戏准星会自动关闭。

### User Key (Gaming Mode)/ Decrease

Customize the function of this shortcut key in the OSD menu: Gaming Mode, Sniper Scope, Frame Counter, Pixel Refresh. The factory default setting is "Gaming Mode".

When there is no OSD, press "v" key to open Gaming mode function, then press "v" or "^" key to select Gaming mode (FPS, RTS, Racing, Gamer 1, Gamer 2 or Gamer 3) basing on the different game types.

### Source/Exit

当 OSD 菜单处于关闭状态时，按此键激活信号源切换功能，连续按此键来选择信息栏中显示的信号源，按菜单键调整为选择的信号源。

当 OSD 菜单处于激活状态时，此按键作为退出键（退出 OSD 菜单）。

# OSD Setting

Basic and simple instruction on the control keys.

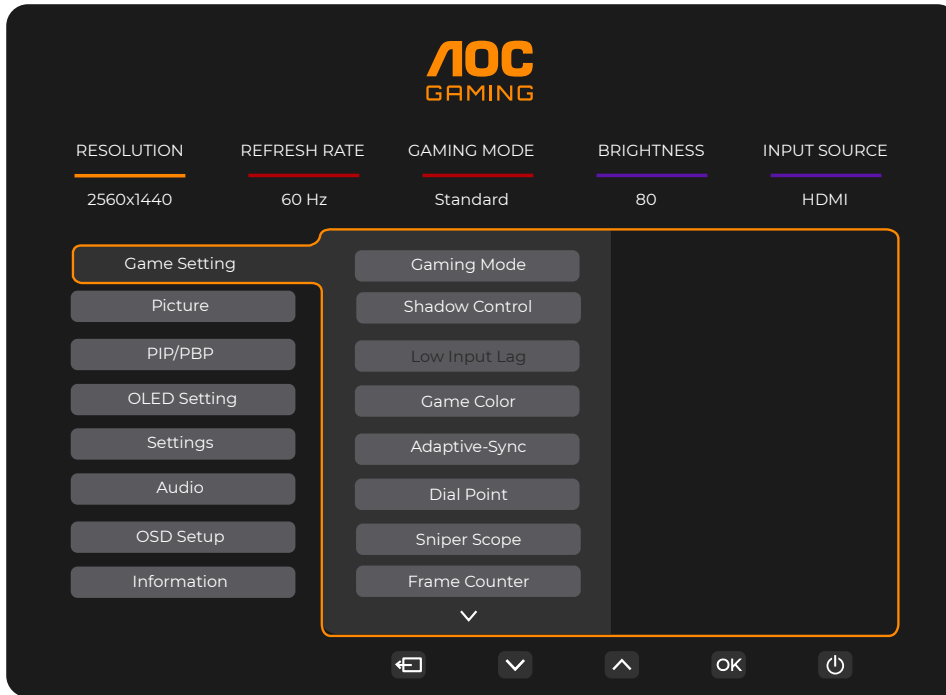

- 1). 按任意键激活虚拟按键，再按 **OK** 键激活 OSD 窗口
- 2). Press **↓** or **↑** to navigate through the functions. Once the desired function is highlighted, press the **OK** to activate it, press **↓** or **↑** to navigate through the sub-menu functions. Once the desired sub-menu function is highlighted, press **OK** to activate it.
- 3). Press **↓** or **↑** to change the settings of the selected function. Press **←** to exit. If you want to adjust any other function, repeat steps 2-3.
- 4). OSD Lock Function: To lock the OSD, press and hold the **OK** button while the monitor is off and then press **(I)** power button to turn the monitor on. To unlock the OSD - press and hold the **OK** button while the monitor is off and then press **(I)** power button to turn the monitor on.

## Game Setting

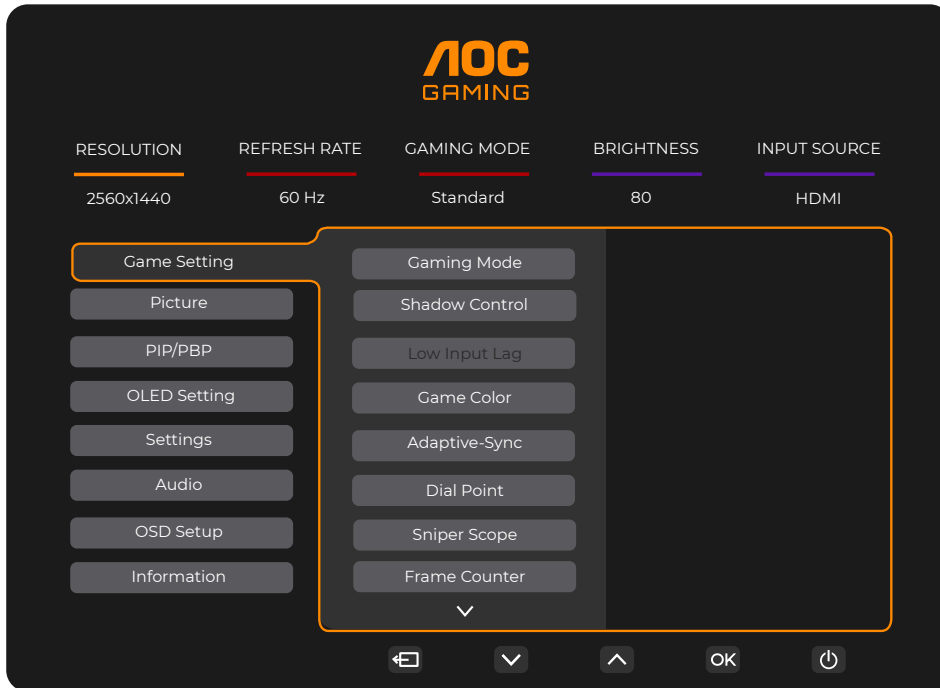

Gaming Mode	Standard	Enhance readability for suitable web and mobile games.
	FPS	For playing FPS (first Person Shooters) games. Improves black level in dark theme.
	RTS	For playing RTS (Real Time Strategy) games. Improves the image quality.
	Racing	For playing Racing games, Provides fastest response time and high color saturation.
	Gamer 1	User's preference settings saved as Gamer 1.
	Gamer 2	User's preference settings saved as Gamer 2.
	Gamer 3	User's preference settings saved as Gamer 3.
Shadow Control	0-20	Shadow Control Default is 0, then end-user can adjust from 0 to 20 increase for a clearer picture. If picture is too dark to be saw the detail clearly, adjusting from 0 to 20 for a clear picture.
Low input Lag	Off/ On	Shutting down the frame buffer can reduce input delay. Note: The Low input Lag function is On by default and cannot be adjusted when Adaptive-Sync is On.
Game Color	0 ~ 20	Game Color will provide 0-20 level for adjusting saturation to get a better picture.
Adaptive-Sync	Off/ On	Disable or Enable Adaptive-Sync/G-SYNC. Adaptive-Sync/G-SYNC Run Reminder: When the Adaptive-Sync/G-SYNC feature is enabled, there may be flashing in some game environments.
Dial Point	Off/Dynamic/On	Turn the game Dial Point function on or off. The game Dial Point is automatically Off after the monitor is On or Off. When the Dial Point function is On, the Dial Point is displayed in the center of the screen to assist players in aiming accurately during first-person shooter (FPS) games.
Sniper Scope	Off / 1.0 / 1.5 / 2.0	Zoom in locally to make it easier to target when shooting.

Frame Counter	Off / Right-up / Right-Down / Left-Up / Left-Down	Display V frequency on the corner selected.
HDMI	Console/ DVD/ PC	Select the type of device connected. When using HDMI to connect the game console or DVD player, set HDMI to the game console/DVD.

**Note:**

- 1). When "HDR Mode" under "Picture" is enable, the items "Shadow Control", "Game Color" cannot be adjusted.
- 2). When "HDR" under "Picture" is set to "DisplayHDR", the items "Gaming Mode", "Shadow Control", "Game Color" can not be adjusted.  
When "HDR" under "Picture" is set to "HDR Peak", "HDR Picture", "HDR Movie" or "HDR Game", the items "Gaming Mode", "Game Color" can not be adjusted.
- 3). When the "Color Space" under "Picture" is set to "sRGB" or "DCI-P3", the items "Shadow Control", "Game Color" cannot be adjusted.

# Picture

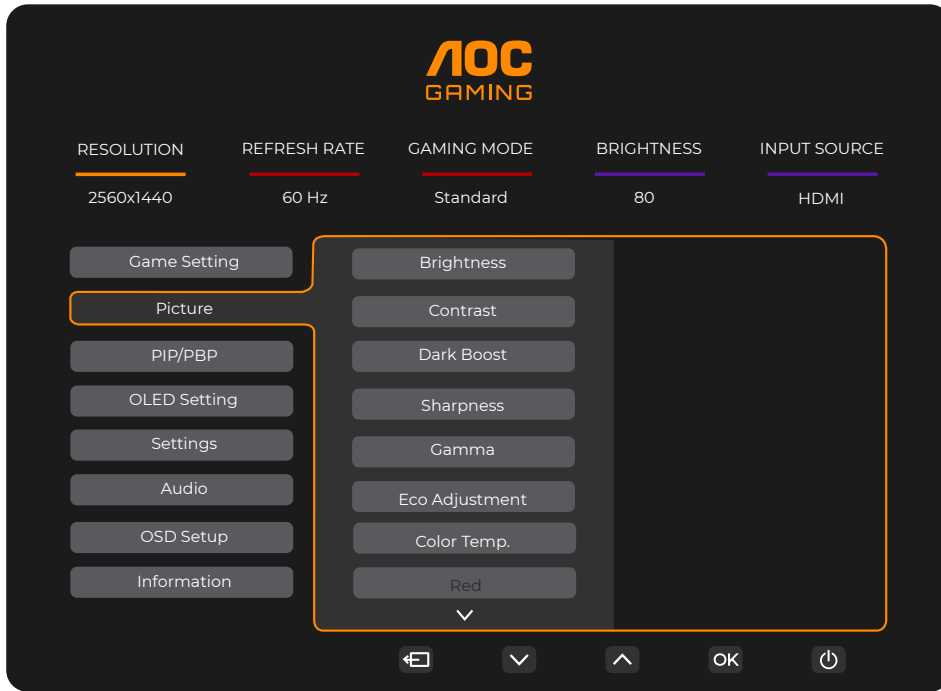

Brightness	0-100	Adjust brightness.
Contrast	0-100	Adjust contrast.
Dark Boost	Off/ Level 1/ Level 2/ Level 3	Enhance the screen details in the dark or bright area to adjust the brightness in the bright area and ensure that it is not oversaturated.
Sharpness	0-100	Adjust Sharpness.
Gamma	1.8 / 2.0 / 2.2 / 2.4 / 2.6	Adjust Gamma.
Eco Adjustment	Standard	Standard Mode.
	Text	Text Mode.
	Internet	Internet Mode.
	Game	Game Mode.
	Movie	Movie Mode.
	Sports	Sports Mode.
Color Temp.	Reading	Reading Mode.
	Warm	Warm Color Temperature .
	Normal	Normal Color Temperature .
	Cool	Cool Color Temperature.
	User	Restore Color Temperature .
Red	0-100	Red gain from Digital-register.
Green	0-100	Green gain from Digital-register.
Blue	0-100	Blue gain from Digital-register.
R.Saturation	0-100	Adjust R.Saturation.
G.Saturation	0-100	Adjust G.Saturation.
B.Saturation	0-100	Adjust B.Saturation.
C.Saturation	0-100	Adjust C.Saturation.
M.Saturation	0-100	Adjust M.Saturation.
Y.Saturation	0-100	Adjust Y.Saturation.

R.Hue	0-100	Adjust R.Hue.
G.Hue	0-100	Adjust G.Hue.
B.Hue	0-100	Adjust B.Hue.
C.Hue	0-100	Adjust C.Hue.
M.Hue	0-100	Adjust M.Hue.
Y.Hue	0-100	Adjust Y.Hue.
HDR	Off	Set the HDR profile according to your usage requirements. Note: When HDR is detected, the HDR option is displayed for adjustment.
	DisplayHDR	
	HDR Peak	
	HDR Picture	
	HDR Movie	
HDR Mode	Off	Optimized for the color and contrast of the picture, which will simulate showing the HDR effect. Note: When HDR is not detected, the HDR Mode option is displayed for adjustment.
	HDR Picture	
	HDR Movie	
	HDR Game	
Color Space	Panel Native	Standard color space panel.
	sRGB	sRGB Color space.
	DCI-P3	DCI-P3 Color space
LowBlue Mode	Off	Decrease blue light wave by controlling color temperature.
	Multimedia	
	Internet	
	Office	
	Reading	
Image Ratio	Full □□□/ Aspect / 1:1/ 17" (4:3)/ 19" (4:3)/ 19" (5:4)/ 19"W (16:10)/ 21.5"W (16:9)/ 22"W (16:10)/ 23"W (16:9)/ 23.6"W (16:9)/ 24"W (16:9)	Select image ratio for display.

**Note:**

- 1). When "HDR Mode" is enable, the items "Contrast", "Dark Boost", "Gamma", "Eco Adjustment", "Color Temp.", "6-Axis Color Saturation/Hue", "Color Space" and "LowBlue Mode" cannot be adjusted.
- 2). When "HDR" is set to "DisplayHDR", all the items under "Picture" except "HDR" and "Sharpness" cannot be adjusted.  
When "HDR" is set to "HDR Peak", "HDR Picture", "HDR Movie" or "HDR Game", the items "Gamma", "Eco Adjustment", "Color Temp.", "6-Axis Color Saturation/Hue", "Color Space" and "LowBlue Mode" cannot be adjusted.
- 3). When the "Color Space" is set to "sRGB" or "DCI-P3", the items "Contrast", "Dark Boost", "Gamma", "Eco Adjustment", "Color Temp.", "6-Axis Color Saturation/Hue", "HDR Mode" and "LowBlue Mode" cannot be adjusted.
- 4). When the "Eco Adjustment" is set to "Reading", "Contrast", "Dark Boost", "Color Temp.", "6-Axis Color Saturation/Hue", "Color Space" and "Low blue mode" cannot be adjusted.
- 5). When the "Gaming Mode" under "Game Setting" is set to non "Standard" mode, the item "Eco Adjustment", "6-Axis Color Saturation/Hue", "HDR Mode" and "Color Space" cannot be adjusted.
- 6). If the input signal resolution is the native resolution or Adaptive-Sync/G-SYNC, then the item "Image Ratio" is invalid.

## PIP/PBP

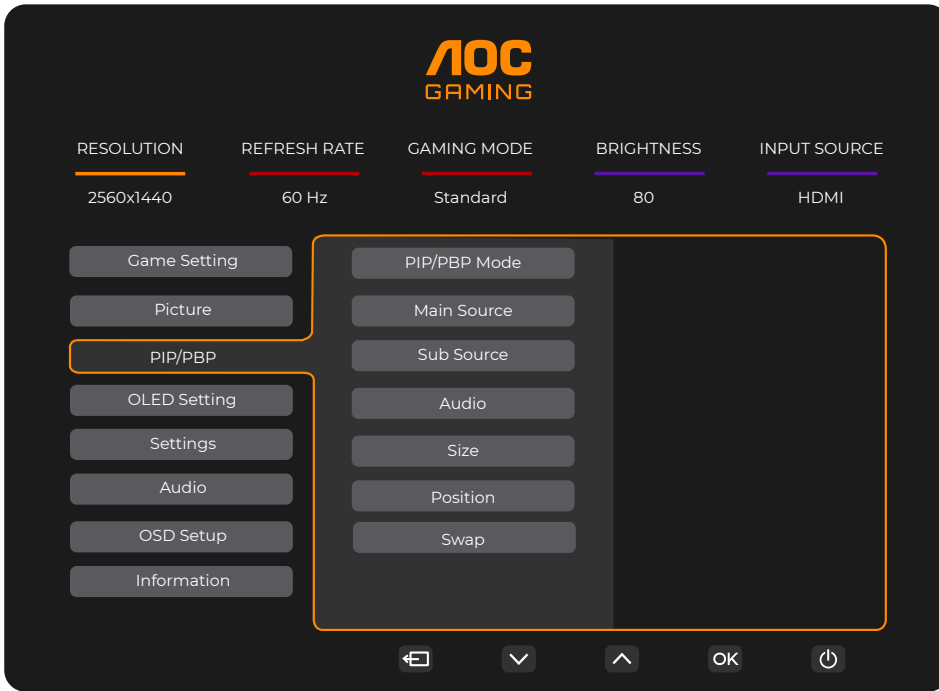

PIP/PBP Mode	Off/PIP/PBP	Disable or enable the PIP and PBP functions.
Main Source	HDMI/DisplayPort	Select the main screen source.
Sub Source	HDMI/DisplayPort	Select the sub screen source.
Audio	Main Source	Select the audio output for the main or sub screen.
	Sub Source	
Size	Small/Middle/Large	Select the sub screen size.
Position	Right-up	Select the sub screen position.
	Right-down	
	Left-up	
	Left-down	
Swap	On: Swap	Swap the screen source
	Off: No action	

### Note:

- 1). When "HDR" under the "Picture" menu is set to any state other than "Off", all items under the "PIP/PBP" menu become unavailable for adjustment.
- 2). When PIP is turned on, the HDMI/DisplayPort signal source supports the maximum resolution of 2560x1440@144Hz. When PBP is turned on, the HDMI signal source supports the maximum resolution of 1280x1440@144Hz; the DisplayPort signal source supports the maximum resolution of 1280x1440@165Hz.
- 3). When PBP/PIP is On, the input source compatibility for the main/sub screens is as shown in the following table:

PBP/PIP		Main source	
		HDMI	DisplayPort
Sub source	HDMI	V	V
	DisplayPort	V	V

## OLED Setting

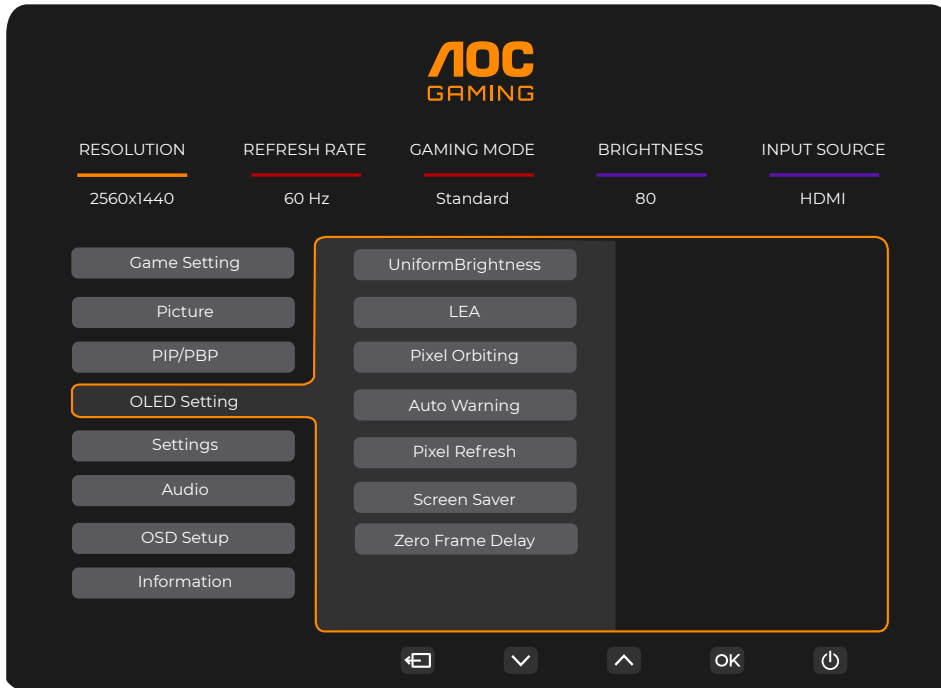

Uniform Brightness	Off/On	Enabling the Uniform Brightness function activates peak brightness stabilization for SDR content, maintaining consistent luminance even when the size of the white window changes.
LEA (Prevention of local image retention)	Off / On	It is used to turn on the LEA function to reduce the risk of generating image retention. Recommended function settings: "On."  After this function is enabled, the screen will be automatically narrowed to fix the brightness of the display area, so as to reduce possible image retention.
Pixel Orbiting (Image shift)	Off	It is used to turn the Pixel Orbiting function on to reduce the risk of generating image retention. Recommended function setting: "On."  After this function is enabled, image pixels will circularly move as a whole. The movement amplitude is based on the settings. The moved character may be side cut. When "Strongest" is selected, image retention is most unlikely generated, but possible side cut may be most notable.
	Weak	
	Medium	
	Strong	
	Strongest	
Auto Warning	Off / On	Enable/Disable the "Pixel Refresh" Auto Warning feature.  The monitor will automatically display an "Auto Warning" every 24 hours of cumulative usage to remind the user to run the "Pixel Refresh" process.  Select "Off" to stop the Auto Warning for "Pixel Refresh." However, if the recommended time for running the " Pixel Refresh " is not followed, it may increase the risk of image retention on the screen. Please proceed with caution.
Pixel Refresh	Off/On	It is used to enable and run the Screen Compensation and Correction and Pixel Refresh functions to eliminate image retention which has been generated. After turning on, select "Yes" according to the menu prompt, and the monitor will automatically run Screen Compensation and Correction first, and then run Pixel Refresh. 结束后，显示器将恢复开机状态。

Screen Saver	Off/On	<p>To reduce the risk of image retention, it is recommended to enable the screen saver function.</p> <p>When a static image is displayed for an extended period, the screen brightness will automatically decrease significantly to mitigate potential image retention. The screen will restore to its previous brightness level once a change in the image is detected.</p>
Zero Frame Delay	Off/On	<p>When enabled, it reduces image latency and improves response time.</p>

# Settings

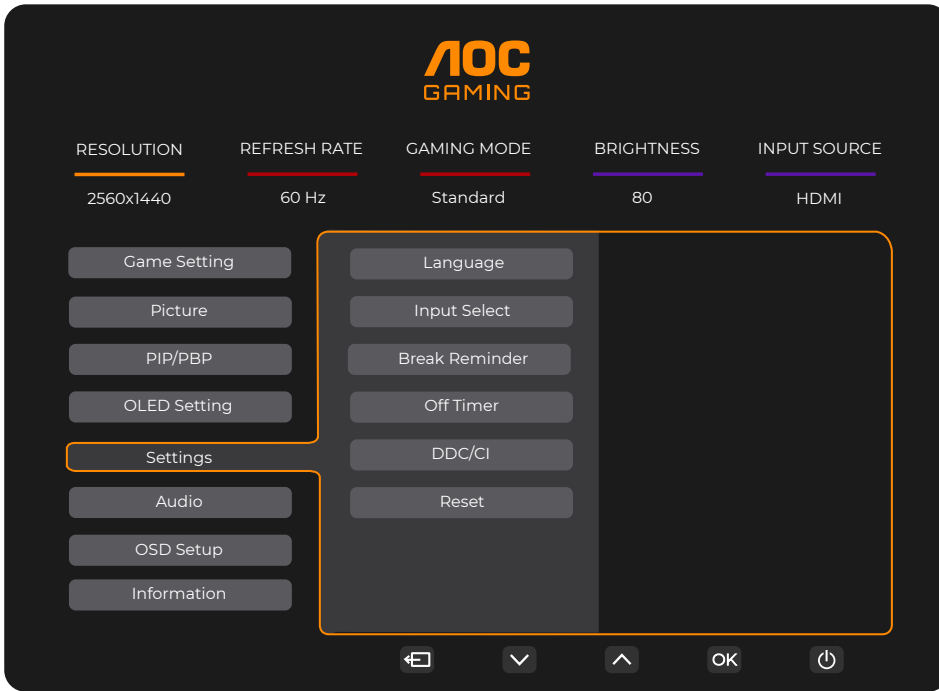

Language		Select the OSD language.
Input Select	HDMI/ DisplayPort	Select Input Signal Source.
Break Reminder	Off/On	When enabled, the system will trigger a rest reminder if the user works continuously for more than 1 hour.
Off Timer	0-24 hrs	Select DC off time.
DDC/CI	No / Yes	Turn On/Off DDC/CI Support.
Reset	No / Yes	Reset the menu to default.

## Audio

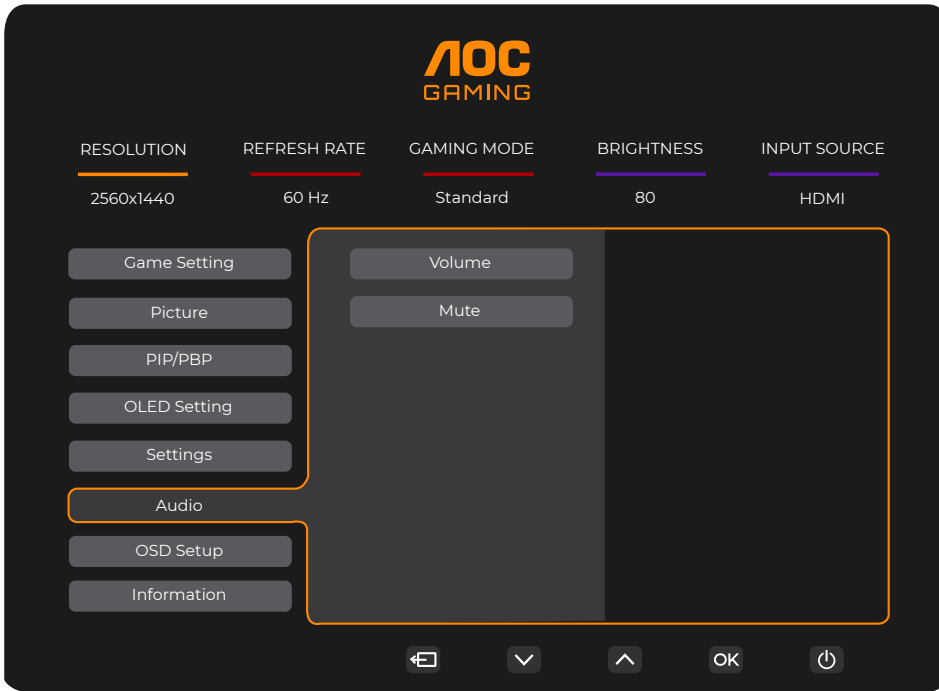

Volume	0-100	Adjust the output volume of the speakers or headphones.
Mute	Off / On	Mute On/Off

## OSD Setup

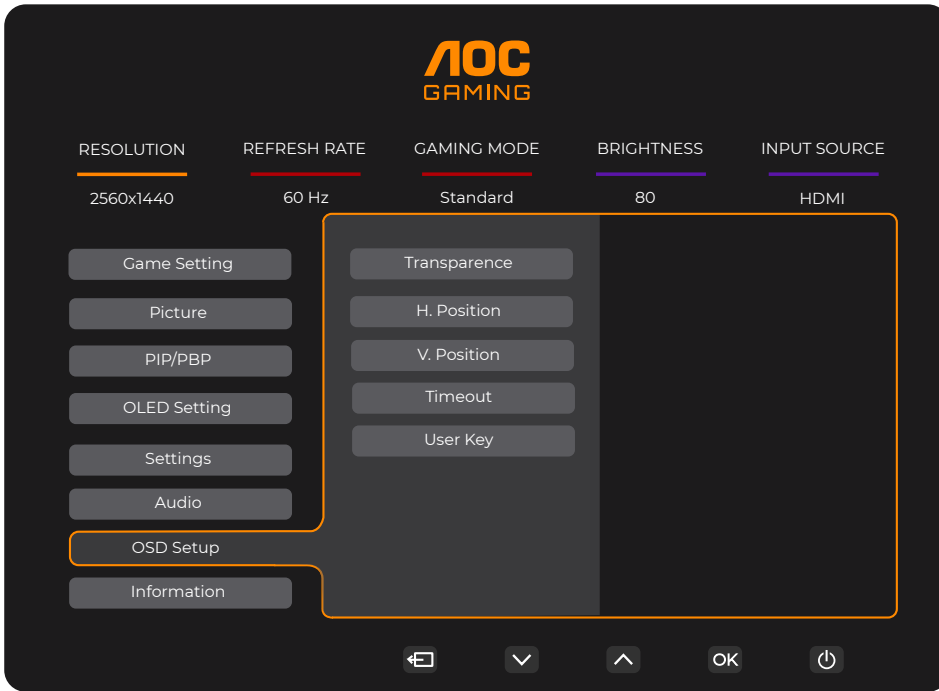

Transparence	0-100	Adjust the transparence of OSD.
H. Position	0-100	Adjust the horizontal position of OSD.
V. Position	0-100	Adjust the vertical position of OSD.
Timeout	5-120	Adjust the OSD Timeout.
User Key	Gaming Mode / Sniper Scope / Frame Counter / Pixel Refresh	User set "v" key shortcut menu.

# Information

**AOC GAMING**

RESOLUTION: 2560x1440  
REFRESH RATE: 60 HZ  
GAMING MODE: Standard  
BRIGHTNESS: 80  
INPUT SOURCE: HDMI

Game Setting  
Picture  
PIP/PBP  
OLED Setting  
Settings  
Audio  
OSD Setup  
Information

Model Name: Q27G41ZDP  
Resolution: 2560(H)x1440(V)/60HZ  
HDR: SDR  
Sync: Adaptive-Sync  
Serial Number: 3213213213210  
Time after Pixel Refresh: 0.9  
Pixel Refresh Counts: 7

Navigation: Back, Down, Up, OK, Power

## LED Indicator

Status	LED Color
Full Power Mode	White
Active-off Mode	Orange
Pixel Refresh under process	Flashing White (1 second on/1 second off)
JB under process	Flashing White (3 seconds on/3 seconds off)
OLED panel malfunction	Flashing Orange (1 second on/1 second off)
Shutdown mode	The indicator is not lit.

# Troubleshoot

Problems	Possible solutions
The power indicator is not lit.	<ul style="list-style-type: none"> <li>• Check if the power is turned on.</li> <li>• Check if the power cord is connected.</li> </ul>
The power indicator is lit, but there is no image display.	<ul style="list-style-type: none"> <li>• Check if the computer power is turned on.</li> <li>• Check if the graphics card of the computer is well plugged.</li> <li>• Check that the signal wire of the display has been correctly connected to the computer.</li> <li>• Check the plug of the signal wire of the display, and make sure all pins are not bent.</li> <li>• Observe the indicator through the Caps Lock key on the keypad of the computer to confirm if the computer is working.</li> </ul>
There is no image, but the power indicator flashes orange.	<ul style="list-style-type: none"> <li>• The OLED panel malfunctions and fails to work properly. Seek advice from AOC after-sales service persons.</li> </ul>
Failure to realize plug-to-use.	<ul style="list-style-type: none"> <li>• Check if it supports plug-to-use.</li> <li>• Check if the adapter supports plug-to-use.</li> </ul>
Dim image.	<ul style="list-style-type: none"> <li>• Adjust luminance and contrast ratio.</li> </ul>
The image is bouncing or rippled.	<ul style="list-style-type: none"> <li>• There may be electrical appliances and devices at the periphery that may cause electronic interference.</li> </ul>
The screen displays “the signal wire is not available” or “no signal.”	<ul style="list-style-type: none"> <li>• Check if the signal wire is correctly connected.</li> <li>• Check if the pin of the signal wire plug is damaged.</li> <li>• The Pixel Refresh function can be enabled and run in the display menu to eliminate image retention which has been generated. Running this function for several times can obtain a desirable image display effect. For other instructions regarding screen maintenance, refer to the User Instructions in the official website.</li> </ul>
The screen displays “invalid input”.	<ul style="list-style-type: none"> <li>• Check if your computer is set in an improper display mode. Please re-set your computer in the display mode listed in the detailed user instructions.</li> </ul>
Image retention.	<ul style="list-style-type: none"> <li>• Based on the characteristics of the OLED panel, the Pixel Refresh function can be enabled and run in the display menu to eliminate image retention which has been generated. It is recommended to run this function for several times to obtain a desirable image display effect. For other instructions regarding screen maintenance, please refer to the User Instructions in the official website.</li> </ul>
Regulation & Service	<ul style="list-style-type: none"> <li>• Please refer to Regulation &amp; Service Information at <a href="http://www.aoc.com">www.aoc.com</a> (to find the model you purchase in your country and to find Regulation &amp; Service Information in Support page.)</li> </ul>

# Specification

## General Specification

Panel	Model name	Q27G41ZDP		
	Driving system	OLED		
	Viewable Image Size	67.3 Diagonal		
	Pixel pitch	0.2292mm(H) x 0.2292mm(V)		
	Display Color	1.07B		
Others	Horizontal scan range	30k~390kHz		
	Horizontal scan Size (Maximum)	586.75 mm		
	Vertical scan range	48~240Hz		
	Vertical Scan Size(Maximum)	330.05 mm		
	Optimal preset resolution	2560x1440@60Hz		
	Max resolution	2560x1440@240Hz		
	Plug & Play	VESA DDC2B/CI		
	Power Source	100-240V~ 50/60Hz 1.6A		
	Power Consumption	Typical(default brightness and contrast)	58W	
Max. (brightness = 100, contrast =100)		≤110W		
Standby Mode		≤ 0.3 W		
Physical Characteristics	Connector Type	HDMI/ DisplayPort/ Earphone		
	Signal Cable Type	Detachable		
Environmental	Temperature	Operating	0°C~40°C	
		Non-Operating	-25°C~55°C	
	Humidity	Operating	10%~85% (Non-Condensing)	
		Non-Operating	5%~93% (Non-Condensing)	
	Altitude	Operating	0m~5000m (0ft~16404ft)	
		Non-Operating	0m~12192m (0ft~40000ft)	

**Note:**

1). The maximum number of display colors supported by this product is 1.07 billion, and the setting conditions are as follows (there may be differences due to the output limitation of some graphics cards):

Input Signal Version Output Color Format State Output Resolution Color Depth	HDMI2.1		DisplayPort1.4	
	YCbcr422 YCbcr420	YCbcr444 RGB	YCbcr422 YCbcr420	YCbcr444 RGB
2560x1440@240Hz 10bpc	Support	Support	Support	Support (DSC)
2560x1440@240Hz 8bpc	Support	Support	Support	Support
2560x1440@200Hz 10bpc	Support	Support	Support	Support
2560x1440@200Hz 8bpc	Support	Support	Support	Support
2560x1440@165Hz 10bpc	Support	Support	Support	Support
2560x1440@165Hz 8bpc	Support	Support	Support	Support
2560x1440@144Hz 10bpc	Support	Support	Support	Support
2560x1440@144Hz 8bpc	Support	Support	Support	Support
2560x1440@120Hz 10bpc	Support	Support	Support	Support
2560x1440@120Hz 8bpc	Support	Support	Support	Support
2560x1440@100Hz 10bpc	Support	Support	Support	Support
2560x1440@100Hz 8bpc	Support	Support	Support	Support
Lower Resolution 10bpc/ 8bpc	Support	Support	Support	Support

2). To achieve QHD 240Hz 1.07 billion (RGB/YCbCr 4:4:4 format) and above resolution, a graphics card that supports DSC must be used for the DisplayPort1.4 (HBR3) signal input. Please consult the graphics card manufacturer for DSC support.

## Preset Display Modes

STANDARD	RESOLUTION (+/-1Hz)	HORIZONTAL FREQUENCY(kHz)	VERTICAL FREQUENCY(Hz)
VGA	640x480@60Hz	31.469	59.94
	640x480@72Hz	37.861	72.809
	640x480@75Hz	37.500	75
	640x480@100Hz	51.08	99.769
	640x480@120Hz	61.91	119.518
SVGA	800x600@56Hz	35.156	56.25
	800x600@60Hz	37.879	60.317
	800x600@72Hz	48.077	72.188
	800x600@75Hz	46.875	75
	800x600@100Hz	63.68	99.662
	800x600@120Hz	77.425	119.854
XGA	1024x768@60Hz	48.363	60.004
	1024x768@70Hz	56.476	70.069
	1024x768@75Hz	60.023	75.029
	1024x768@100Hz	81.577	99.972
	1024x768@120Hz	97.551	119.989
SXGA	1280x1024@60Hz	63.981	60.02
	1280x1024@75Hz	79.976	75.025
FHD	1920x1080@60Hz	67.5	60
QHD	2560x1440@60Hz	88.86	60.001
	2560x1440@100Hz	151	100
	2560x1440@120Hz	183	120
	2560x1440@144Hz	222.194	144.001
	2560x1440@165Hz	242.551	165
	2560x1440@200Hz	294	200
	2560x1440@240Hz	385.2	240
PBP	1280x1440@60Hz	89.45	59.913
	1280x1440@75Hz	111.972	74.998
	1280x1440@100Hz	149.3	100
	1280x1440@120Hz	179.157	119.998
	1280x1440@144Hz	214.994	144.002
	1280x1440@165Hz	246.347	165.002
MAC MODES			
VGA	640x480@67Hz	35	66.667
SVGA	832x624@75Hz	49.725	74.55
IBM MODES			
DOS	720x400@70Hz	31.469	70.087

**Note:**

According to the VESA standard, there may be a certain error (+/-1Hz) when calculating the refresh rate (field frequency) of different operating systems and graphics cards. In order to improve compatibility, the nominal refresh rate of this product has been rounded off. Please refer to the actual product.

## Pin Assignments



19-Pin Color Display Signal Cable

Pin No.	Signal Name	Pin No.	Signal Name	Pin No.	Signal Name
1.	TMDS Data 2+	9.	TMDS Data 0-	17.	DDC/CEC Ground
2.	TMDS Data 2 Shield	10.	TMDS Clock +	18.	+5V Power
3.	TMDS Data 2-	11.	TMDS Clock Shield	19.	Hot Plug Detect
4.	TMDS Data 1+	12.	TMDS Clock-		
5.	TMDS Data 1Shield	13.	CEC		
6.	TMDS Data 1-	14.	Reserved (N.C. on device)		
7.	TMDS Data 0+	15.	SCL		
8.	TMDS Data 0 Shield	16.	SDA		

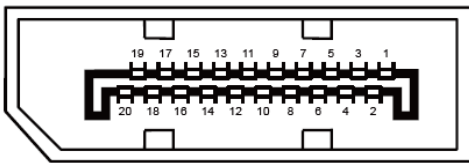

20-Pin Color Display Signal Cable

Pin No.	Signal Name	Pin No.	Signal Name
1	ML_Lane 3 (n)	11	GND
2	GND	12	ML_Lane 0 (p)
3	ML_Lane 3 (p)	13	CONFIG1
4	ML_Lane 2 (n)	14	CONFIG2
5	GND	15	AUX_CH(p)
6	ML_Lane 2 (p)	16	GND
7	ML_Lane 1 (n)	17	AUX_CH(n)
8	GND	18	Hot Plug Detect
9	ML_Lane 1 (p)	19	Return DisplayPort_PWR
10	ML_Lane 0 (n)	20	DisplayPort_PWR

# Plug and Play

## Plug & Play DDC2B Feature

This monitor is equipped with VESA DDC2B capabilities according to the VESA DDC STANDARD. It allows the monitor to inform the host system of its identity and, depending on the level of DDC used, communicate additional information about its display capabilities.

The DDC2B is a bi-directional data channel based on the I2C protocol. The host can request EDID information over the DDC2B channel.

