



EMC TEST REPORT

Applicant : TPV Electronics (Fujian) Co., Ltd.
Address : Rongqiao Economic and Technological Development Zone, Fuqing City
Equipment : OLED MONITOR
Test Model : AGP277QKDC
Series Model : AGP277*****.***277Q***** (The "*" could be any alphanumeric character including blank for marketing differentiation.)
Brand Name : AOC
Date of sample receipt : Oct. 29, 2025
Date(s) of test : Nov. 05, 2025 ~ Nov. 10, 2025
Standard : EN 55032, EN 55035, CISPR 32, CISPR 35, AS/NZS CISPR 32, EN IEC 61000-3-2, EN 61000-3-3, BS EN 55032, BS EN 55035, BS EN IEC 61000-3-2, BS EN 61000-3-3

I HEREBY CERTIFY THAT:

The test result refers exclusively to the test presented test model / sample. Without written approval of CerpPASS Technology Corp., the test report shall not be reproduced except in full.

Approved by:

Leevin Li / Supervisor



Contents

- 1. Summary of Test Procedure and Test Results..... 5**
- 2. Immunity Testing Performance Criteria Definition 6**
- 3. Test Configuration of Equipment under Test 7**
 - 3.1. Feature of Equipment under Test..... 7
 - 3.2. Test Manner 8
 - 3.3. Description of Support Unit 9
 - 3.4. General Information of Test..... 10
 - 3.5. Measurement Uncertainty 10
- 4. Test of Conducted Emission 11**
 - 4.1. Test Limit 11
 - 4.2. Test Procedures 13
 - 4.3. Typical Test Setup 13
 - 4.4. Test Result and Data 14
- 5. Test of Radiated Emission 17**
 - 5.1. Test Limit 17
 - 5.2. Test Procedures 19
 - 5.3. Typical Test Setup 20
 - 5.4. Test Result and Data (30MHz ~ 1GHz) 21
 - 5.5. Test Result and Data (Above 1GHz)..... 23
- 6. Harmonics Test..... 25**
 - 6.1. Limits of Harmonics Current Measurement 25
 - 6.2. Test Result and Data 26
- 7. Voltage Fluctuations Test 30**
 - 7.1. Test Procedure 30
 - 7.2. Test Result and Data 30
- 8. Electrostatic Discharge Immunity Test 32**
 - 8.1. Test Procedure 32
 - 8.2. Test Setup for Tests Performed in Laboratory 33
 - 8.3. Test Severity Levels 33
 - 8.4. Test Result and Data 35
- 9. Radio Frequency electromagnetic field immunity test 37**
 - 9.1. Test Procedure 37
 - 9.2. Test Severity Levels 37
 - 9.3. Test Result and Data 38
- 10. Electrical Fast Transient/ Burst Immunity Test 40**
 - 10.1. Test Procedure 40
 - 10.2. Test Severity Levels 40
 - 10.3. Test Result and Data 41
- 11. Surge Immunity Test 42**
 - 11.1. Test Procedure 42
 - 11.2. Test Severity Level 42
 - 11.3. Test Result and Data 43



12. Conduction Disturbances induced by Radio-Frequency Fields 44
 12.1. Test Procedure 44
 12.2. Test Severity Levels 44
 12.3. Test Result and Data 45
13. Power Frequency Magnetic Field Immunity Test 47
 13.1. Test Setup 47
 13.2. Test Severity Levels 47
 13.3. Test Result and Data 48
14. Voltage Dips and Voltage Interruptions Immunity Test Setup 49
 14.1. Test Conditions 49
 14.2. TEST SETUP 49
 14.3. Test Result and Data 50
15. Photographs of the test configuration 51
16. List of Measuring Equipment 58
 Appendix A-PHOTOGRAPHS OF EUT



History of this test report

Version No.	Report No	Date	Description
Rev.01	25100325-DECE01	Nov. 11, 2025	Initial Issue



1. Summary of Test Procedure and Test Results

The measurements shown in this test report were made in accordance with the procedures given in **EUROPEAN COUNCIL DIRECTIVE 2014/30/EU**.

The energy emitted by this equipment was passed both Radiated and Conducted Emissions Class **B** limits.

Test Item	Normative References	Test Result
Conducted Emission	EN 55032:2015 EN 55032:2015+A11:2020	PASS
Telecom Port Conducted Emissions	EN 55032:2015+A1:2020 CISPR 32:2015 CISPR 32:2015/AMD1:2019	N/A
Radiated Emission	BS EN 55032:2015 BS EN 55032:2015+A11:2020 BS EN 55032:2015+A1:2020 AS/NZS CISPR 32:2015 AS/NZS CISPR 32:2015/AMD1:2020	PASS
Harmonics	EN 61000-3-2:2014 EN IEC 61000-3-2 2019/A1:2021 EN IEC 61000-3-2:2019/A2:2024 BS EN 61000-3-2:2014 BS EN IEC 61000-3-2:2019 +A1:2021 BS EN IEC 61000-3-2:2019+A2:2024	PASS
Voltage Fluctuations	EN 61000-3-3:2013/A2:2021/AC:2022-01 BS EN 61000-3-3:2013+A2:2021(2022)	PASS
EN 55035: 2017, CISPR 35: 2016, BS EN 55035: 2017 EN 55035:2017+A11:2020, BS EN 55035:2017+A11:2020		
Electrostatic Discharge Immunity Test (ESD)	IEC 61000-4-2:2025	PASS
Radio Frequency electromagnetic field immunity test (RS)	IEC 61000-4-3:2020	PASS
Electrical Fast Transient/ Burst Immunity Test (EFT)	IEC 61000-4-4:2012	PASS
Surge Immunity Test	IEC 61000-4-5:2014/AMD1:2017	PASS
Conduction Disturbances induced by Radio-Frequency Fields	IEC 61000-4-6:2023	PASS
Power Frequency Magnetic Field Immunity Test	IEC 61000-4-8:2009	PASS
Voltage Dips and Voltage Interruptions Immunity Test	IEC 61000-4-11:2020/COR2:2022	PASS
<p>Note: Deviations Yes <input type="checkbox"/> No <input checked="" type="checkbox"/></p> <p>“N/A” denotes test is not applicable in this test report.</p> <p>*The lab has reduced the uncertainty risk factor from test equipment, environment and staff technicians which according to the standard on contract. Therefore, the test result will only be determined by standard requirement, measurement uncertainty evaluation is not considered.</p>		



2. Immunity Testing Performance Criteria Definition

Criteria A:	The apparatus shall continue to operate as intended without operator intervention. No degradation of performance or loss of function is allowed below a performance level specified by the manufacturer, when the apparatus is used as intended. The performance level may be replaced by a permissible loss of performance. If the manufacturer does not specify the minimum performance level or the permissible performance loss, then either of these may be derived from the product description and documentation, and by what the user may reasonably expect from the equipment if used as intended.
Criteria B:	After test, the apparatus shall continue to operate as intended without operator intervention. No degradation of performance or loss of function is allowed, after the application of the phenomenon below a performance level specified by the manufacturer, when the apparatus is used as intended. The performance level may be replaced by a permissible loss of performance. During the test, degradation of performance is however allowed. However, no change of operating state if stored data is allowed to persist after the test. If the manufacturer does not specify the minimum performance level or the permissible performance loss, then either of these may be derived from the product description and documentation, and by what the user may reasonably expect from the equipment if used as intended.
Criteria C:	Temporary loss of function is allowed, provided the functions is self-recoverable or can be restored by the operation of controls by the user in accordance with the manufacturer instructions. Functions, and/or information stored in non-volatile memory, or protected by a battery backup, shall not be lost.



3. Test Configuration of Equipment under Test

3.1. Feature of Equipment under Test

Product Name:	OLED MONITOR
Test Model:	AGP277QKDC
Series Model:	AGP277*****;***277Q***** (The “*” could be any alphanumeric character including blank for marketing differentiation.)
Model Discrepancy:	All models are identical except for the name.
EUT Highest Frequency:	2353.02MHz
Power Rating:	100V - 240V~, 50-60Hz
AC Power Cord Type:	Non-shielded, 1.8m & 1.5m
HDMI Cable:	Shielded, 1.8m & 1.5m
DP Cable:	Shielded, 1.8m & 1.5m
USB cable (A TO B) 3.0:	Shielded, 1.8m & 1.5m
Type-C to C&A cable:	Shielded, 1.8m & 1.5m

Note: For detailed information please refer to the user manual.

Serial: AGP277QKDC	--
Test Model: AGP277QKDC	--
Version No.: AGP277*****	Specific sales territory
Version No.: ***277Q*****	

I/O PORT

I/O PORT TYPE	Quantity
1) Power Port	1
2) HDMI Port	2
3) DP Port	1
4) Type-C Port	1
5) Touch USB Port	1
6) USB Port	3
7) Earphone Port	1



3.2. Test Manner

- a. During testing, the interface cables and equipment positions were varied according to Europe Standard EN55032+EN55035.
- b. The test modes of EMC+EMS test are as follows:

Conducted Emission for AC main power/ Radiated Emissions	
Mode 1	Full system (HDMI1 mode 2560*1440@540Hz +USB-B:KVM) Signal from PC with +USB*3 to U Disk+USB-C to Load(20V/3.25A)+Built-in speaker For 230V(Horizontal)
Mode 2	Full system (HDMI2 mode 2560*1440@540Hz +USB-B:KVM) Signal from PC with +USB*3 to U Disk+USB-C to Load(20V/3.25A)+Built-in speaker For 230V(Horizontal)
Mode 3	Full system (HDMI1 mode 1920*1080@60Hz +USB-B:KVM) Signal from DVD with +USB*3 to U Disk+USB-C to Load(20V/3.25A)+Built-in speaker For 230V(Horizontal)
Mode 4	Full system (DP mode 2560*1440@540Hz +USB-B:KVM) Signal from PC with +USB*3 to U Disk+USB-C to Load(20V/3.25A)+Built-in speaker For 230V(Horizontal)
Mode 5	Full system (USB-C mode 2560*1440@540Hz +USB-B:KVM) Signal from PC with +USB*3 to U Disk +Built-in speaker For 230V(Horizontal)
Mode 6	Full system (HDMI1 mode 2560*1440@540Hz +USB-B:KVM) Signal from PC with +USB*2 to U Disk+USB1 to Load(5V/1.5A) +USB-C to Load(20V/3.25A)+Built-in speaker For 230V(Horizontal)
Mode 7	Full system (HDMI1 mode 2560*1440@540Hz +USB-B:KVM) Signal from PC with +USB*3 to U Disk+USB-C to Load(12V/3 A)+Built-in speaker For 230V(Horizontal)
Mode 8	Full system (HDMI1 mode 2560*1440@540Hz +USB-B:KVM) Signal from PC with +USB*3 to U Disk+USB-C to Load(5V/3A)+Built-in speaker For 230V(Horizontal)
Mode 9	Full system (HDMI1 mode 2560*1440@540Hz +USB-B:KVM) Signal from PC with +USB*3 to U Disk+USB-C to Load(20V/3.25A)+Built-in speaker For 230V(Vertical)
Mode 10	Full system (HDMI1 mode 2560*1440@540Hz +USB-B:KVM) Signal from PC with +USB*3 to U Disk+USB-C to Load(20V/3.25A)+Earphone For 230V(Horizontal)
Mode 11	Full system (HDMI1 mode 1920*1080@75Hz +USB-B:KVM) Signal from PC with +USB*3 to U Disk+USB-C to Load(20V/3.25A)+Built-in speaker For 230V(Horizontal)
Mode 12	Full system (HDMI1 mode 640*480@75Hz +USB-B:KVM) Signal from PC with +USB*3 to U Disk+USB-C to Load(20V/3.25A)+Built-in speaker For 230V(Horizontal)
Mode 13	Full system (HDMI1 mode 2560*1440@540Hz +USB-B:KVM) Signal from PC with +USB*3 to U Disk+USB-C to Load(20V/3.25A)+Built-in speaker For 110V(Horizontal)
The "Test Mode 1" generated the worst test result; it was reported as final data	
Conducted Emission for telecom port	



N/A	
Harmonics / Flicker Emissions / EMS (ESD/EFT/SURGE/CS/RS)	
Mode 1	Full system (HDMI1 mode 2560*1440@540Hz +USB-B:KVM) Signal from PC with +USB*3 to U Disk+USB-C to Load(20V/3.25A)+Built-in speaker For 230V(Horizontal)
The “Test Mode 1” generated the worst test result; it was reported as final data	
DIPS/PMF	
Mode 1	Full system (HDMI1 mode 2560*1440@540Hz +USB-B:KVM) Signal from PC with +USB*3 to U Disk+USB-C to Load(20V/3.25A)+Built-in speaker For 230V(Horizontal)
Mode 13	Full system (HDMI1 mode 2560*1440@540Hz +USB-B:KVM) Signal from PC with +USB*3 to U Disk+USB-C to Load(20V/3.25A)+Built-in speaker For 110V(Horizontal)
The “Test Mode 1, 13” generated the worst test result; it was reported as final data	

c. The maximum operating frequency is above 108MHz, the test frequency range is from 30MHz to 6GHz.

3.3. Description of Support Unit

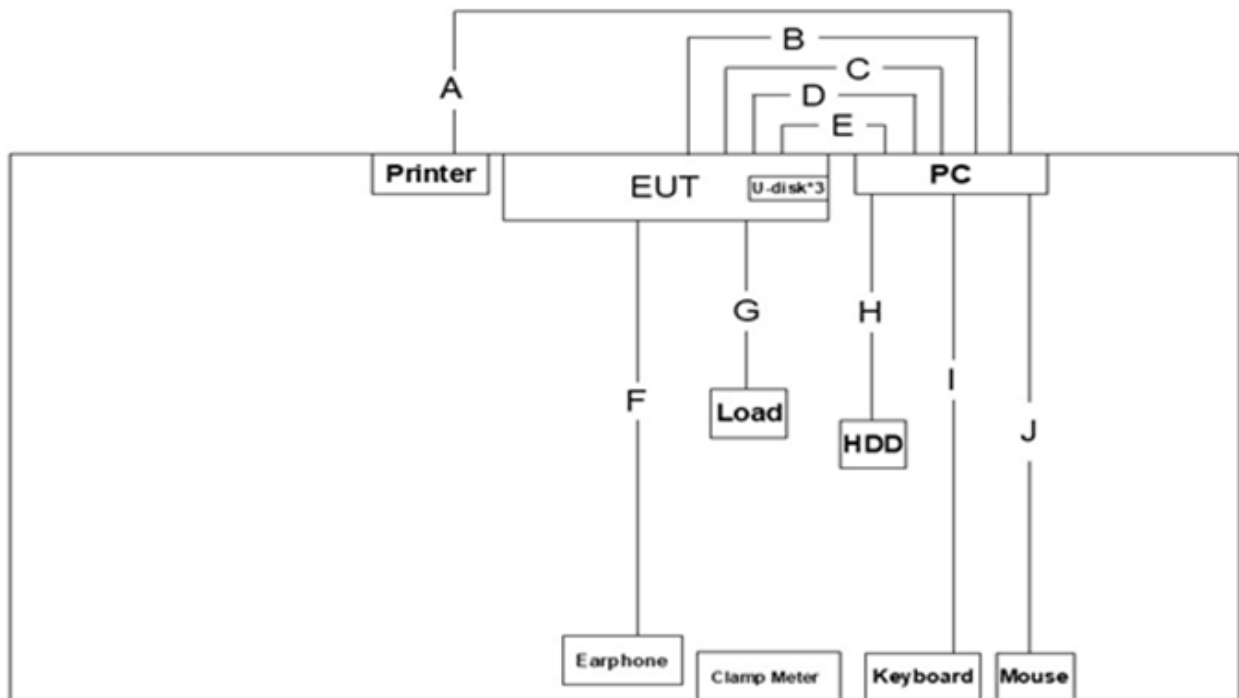

No.	Device	Manufacturer	Model No.	Description
1	PC	DELL	XPS 8920	1.8m Non Shielding
2	Keyboard	DELL	SK-8120	N/A
3	Mouse	DELL	MS116c	N/A
4	Printer	ZEBRA	TLP2824	1.8m Non Shielding
5	HDD	Transcend	TS2TSJ25M3C	N/A
6	U-disk*3	Transcend	16G	N/A
7	Earphone	Logitech	A-00029	N/A



8	Load	N/A	N/A	N/A
9	Clamp Meter	UNI-T	UT221	N/A

No.	Cable	Quantity	Description
A	USB Printer Cable	1	1.8m Shielding
B	HDMI Cable	1	1.5m&1.8m Shielding
C	DP Cable	1	1.5m&1.8m Shielding
D	HDMI Cable	1	1.5m&1.8m Shielding
E	USB Cable	1	1.5m&1.8m Shielding
F	Audio Cable	1	1.5m NonShielding
G	Type-C Cable+USB Cable	1	1.5m Shielding +0.5m NonShielding
H	USB HDD Cable	1	0.5m Shielding
I	USB Keyboard Cable	1	1.8m Shielding
J	USB Mouse Cable	1	1.8m Shielding

3.4. General Information of Test

Test Site	CerpPASS Technology (Dongguan) Co., Ltd. Address: Room 102, No. 5, Chang'an Xing'an Road, Dongguan, Guangdong, China Tel: +86-769-8547-1212 Fax: +86-769-8547-1912
Frequency Range Investigated	Conducted Emission Test: from 150kHz to 30 MHz Radiated Emission Test: from 30 MHz to 1,000 MHz Radiated Emission Test: from 1GHz to 6GHz
Test Distance	The test distance of radiated emission below 1GHz from antenna to EUT is 10 m. The test distance of radiated emission above 1GHz from antenna to EUT is 3 m.

3.5. Measurement Uncertainty

Where relevant, the following measurement uncertainty levels have been estimated for tests performed on the EUT as specified in CISPR 16-4-2:

Conducted Emission	
The measurement uncertainty is evaluated as $\pm 2.52\text{dB}$.	
Conducted Emission (Telecom port)	
The measurement uncertainty is evaluated as $\pm 3.46\text{dB}$.	
Radiated Emission	
(30MHz -1000MHz)	The measurement uncertainty is evaluated as $\pm 4.35\text{dB}$.
(1000MHz-6000MHz)	The measurement uncertainty is evaluated as $\pm 5.56\text{dB}$.

This uncertainty represents an expanded uncertainty expressed at approximately the 95% confidence level using a coverage factor of $k=2$.



4. Test of Conducted Emission

4.1. Test Limit

Conducted Emissions were measured from 150 kHz to 30 MHz with a bandwidth of 9 kHz and return leads of the EUT according to the methods defined in European Standard EN 55032.

Requirements for conducted emissions from the AC mains power ports of Class A equipment

Table clause	Frequency range MHz	Coupling device (see Table A.8)	Detector type / bandwidth	Class A limits dB(μ V)
A9.1	0.15 – 0.5	AMN	Quasi Peak / 9 kHz	79
	0.5 - 30			73
A9.2	0.15 – 0.5	AMN	Average / 9 kHz	66
	0.5 - 30			60

NOTE Apply A9.1 and A9.2 across the entire frequency range.

Requirements for conducted emissions from the AC mains power ports of Class B equipment

Table clause	Frequency range MHz	Coupling device (see Table A.8)	Detector type / bandwidth	Class B limits dB(μ V)
A10.1	0.15 – 0.5	AMN	Quasi Peak / 9 kHz	66 – 56
	0.5 - 5			56
	5 - 30			60
A10.2	0.15 – 0.5	AMN	Average / 9 kHz	56 – 46
	0.5 - 30			46
	5 - 30			50

NOTE Apply A10.1 and A10.2 across the entire frequency range.

Requirements for asymmetric mode conducted emissions from Class A equipment

Table clause	Frequency range MHz	Coupling device (see Table A.8)	Detector type / bandwidth	Class A voltage limits dB(μ V)	Class A current limits dB(μ A)
A11.1	0.15 – 0.5	AAN	Quasi Peak / 9 kHz	97 – 87	n/a
	0.5 - 30			87	
	0.15 – 0.5	AAN	Average / 9 kHz	84 – 74	
	0.5 - 30			74	
A11.3	0.15 – 0.5	Current Probe	Quasi Peak / 9 kHz	n/a	53 – 43
	0.5 - 30				43
	0.15 – 0.5	Current Probe	Average / 9 kHz		40 - 30
	0.5 - 30				30

NOTE 1 The choice of coupling device and measurement procedure is defined in Annex C.

NOTE 2 AC mains ports that also have the function of a wired network port shall meet the limits given in Table A.9.

NOTE 3 The measurement shall cover the entire frequency range

NOTE 4 The application of the voltage and/or current limits is dependent on the measurement procedure used. Refer to Table C.1 for applicability.

NOTE 5 Testing is required at only one EUT supply voltage and frequency.

NOTE 6 Applicable to ports listed above and intended to connect to cables longer than 3 m.



Requirements for asymmetric mode conducted emissions from Class B equipment

Table clause	Frequency range MHz	Coupling device (see Table A.8)	Detector type / bandwidth	Class B voltage limits dB(μV)	Class B current limits dB(μA)
A12.1	0.15 – 0.5	AAN	Quasi Peak / 9 kHz	84 – 74	n/a
	0.5 - 30			74	
	0.15 – 0.5	AAN	Average / 9 kHz	74 – 64	
	0.5 - 30			64	
A12.3	0.15 – 0.5	Current Probe	Quasi Peak / 9 kHz	n/a	40 – 30
	0.5 - 30				30
	0.15 – 0.5	Current Probe	Average / 9 kHz		30 - 20
	0.5 - 30				20

NOTE 1 The choice of coupling device and measurement procedure is defined in Annex C.
 NOTE 2 Screened ports including TV broadcast receiver tuner ports are measured with a common-mode impedance of 150 Ω. This is typically accomplished with the screen terminated by 150 Ω to earth.
 NOTE 3 AC mains ports that also have the function of a wired network port shall meet the limits given in Table A.10.
 NOTE 4 The measurement shall cover the entire frequency range.
 NOTE 5 The application of the voltage and/or current limits is dependent on the measurement procedure used. Refer to Table C.1 for applicability.
 NOTE 6 Measurement is required at only one EUT supply voltage and frequency.
 Applicable to ports listed above and intended to connect to cables longer than 3 m.

Requirements for conducted differential voltage emissions from Class B equipment

Table clause	Frequency range MHz	Detector type/ bandwidth	Class B limits dB(mV) 75 Ω			Applicability	
			Other	Local Oscillator Fundamental	Local Oscillator Harmonics		
A13.1	30 to 950	For frequencies ≤ 1 GHz Quasi Peak/ 120 kHz	46	46	46	See ^a	
	950 to 2 150		46	54	54		
A13.2	950 to 2 150		46	54	54	See ^b	
A13.3	30 to 950		For frequencies ≥ 1 GHz Peak/ 1 MHz	46	54	50	See ^c
	950 to 2 150					52	
A13.4	30 to 950			46	66	59	See ^d
	950 to 2 150	1					
A13.5	30 to 950	46	76	46	See ^e		
	950 to 2 150			n/a		54	

a Television receivers (analogue or digital), video recorders and PC TV broadcast receiver tuner cards working in channels between 30 MHz and 1 GHz, and digital audio receivers.
 b Tuner units (not the LNB) for satellite signal reception.
 c Frequency modulation audio receivers and PC tuner cards.
 d Frequency modulation car radios.
 e Applicable to EUTs with RF modulator output ports (for example DVD equipment, video recorders, camcorders and decoders etc.) designed to connect to TV broadcast receiver tuner ports. Limits specified for the LO are for the RF modulator carrier signal and harmonics.
 The term 'other' refers to all emissions other than the fundamental and the harmonics of the LO.
 The measurement shall cover the entire frequency range.
 The EUT shall be tuned in accordance with Table B.3 and clause C.4.2.1.



4.4. Test Result and Data

4.4.1 Conducted Emission for Power Port Test Data

Test Mode:	Test Mode 1	Test Engineer	Nunu
Power:	AC 230V/50Hz	Phase:	LINE
Temperature:	23°C	Humidity:	56%
EUT:	AGP277QKDC		

Note: Level = Reading + Factor
 Margin = Level – Limit
 Factor = (LISN or ISN or PLC or Current Probe) Factor + Cable Loss + Attenuator

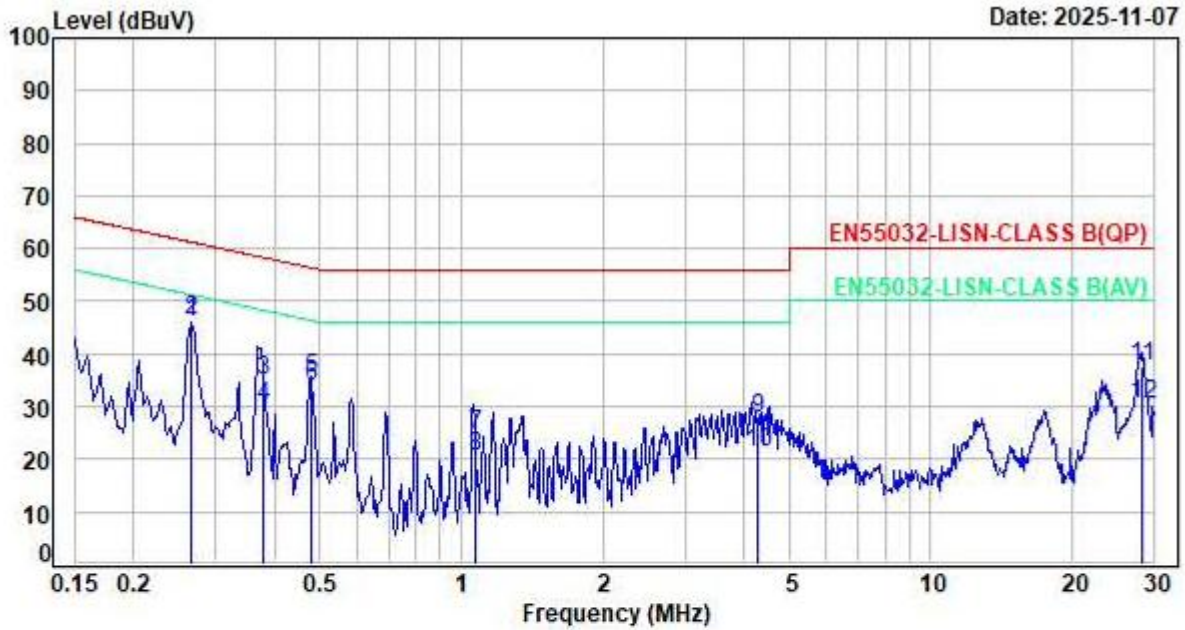

No.	Frequency (MHz)	Factor (dB)	Reading (dBuV)	Level (dBuV)	Limit (dBuV)	Margin (dB)	Detector	P/F
1	0.27	10.35	35.76	46.11	61.26	-15.15	QP	P
2	0.27	10.35	35.90	46.25	51.26	-5.01	Average	P
3	0.38	10.34	24.71	35.05	58.32	-23.27	QP	P
4	0.38	10.34	19.82	30.16	48.32	-18.16	Average	P
5	0.48	10.35	25.07	35.42	56.33	-20.91	QP	P
6	0.48	10.35	23.58	33.93	46.33	-12.40	Average	P
7	1.08	10.34	14.23	24.57	56.00	-31.43	QP	P
8	1.08	10.34	10.12	20.46	46.00	-25.54	Average	P
9	4.27	10.44	17.43	27.87	56.00	-28.13	QP	P
10	4.27	10.44	10.82	21.26	46.00	-24.74	Average	P
11	28.13	11.07	26.43	37.50	60.00	-22.50	QP	P
12	28.13	11.07	19.25	30.32	50.00	-19.68	Average	P



Test Mode:	Test Mode 1	Test Engineer	Nunu
Power:	AC 230V/50Hz	Phase:	NEUTRAL
Temperature:	23° C	Humidity:	56%
EUT:	AGP277QKDC		

Note: Level = Reading + Factor
 Margin = Level – Limit
 Factor = (LISN or ISN or PLC or Current Probe) Factor + Cable Loss + Attenuator

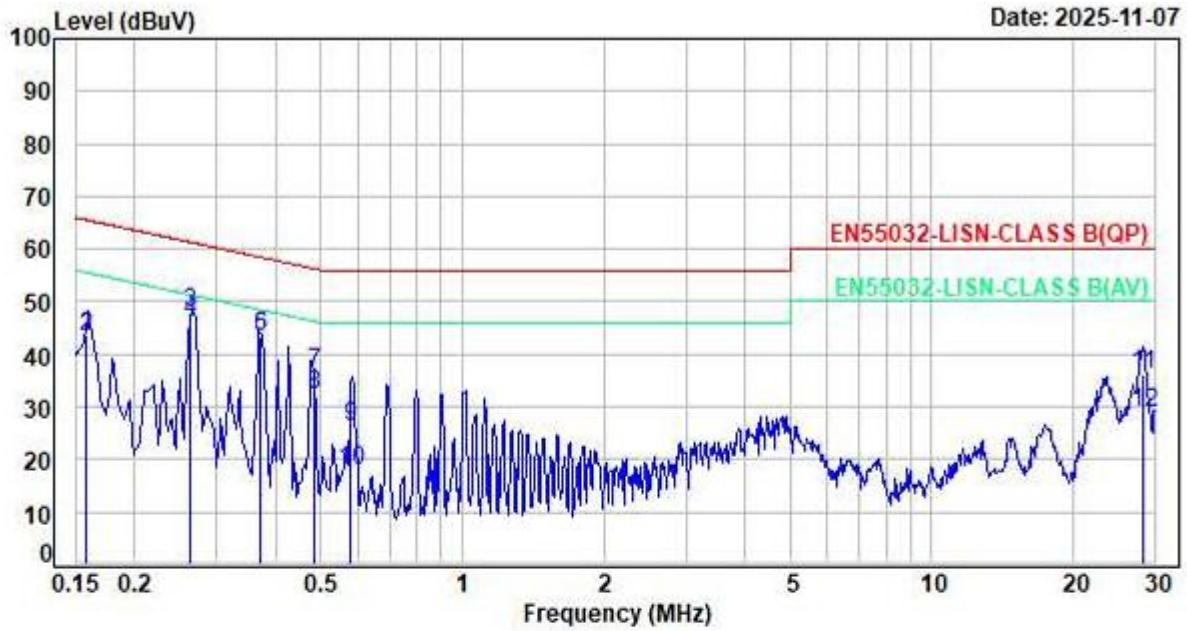

No.	Frequency (MHz)	Factor (dB)	Reading (dBuV)	Level (dBuV)	Limit (dBuV)	Margin (dB)	Detector	P/F
1	0.16	10.30	33.49	43.79	65.58	-21.79	QP	P
2	0.16	10.30	33.17	43.47	55.58	-12.11	Average	P
3	0.26	10.29	37.65	47.94	61.30	-13.36	QP	P
4	0.26	10.29	36.22	46.51	51.30	-4.79	Average	P
5	0.37	10.28	33.06	43.34	58.46	-15.12	QP	P
6	0.37	10.28	32.90	43.18	48.46	-5.28	Average	P
7	0.48	10.30	26.25	36.55	56.28	-19.73	QP	P
8	0.48	10.30	21.89	32.19	46.28	-14.09	Average	P
9	0.58	10.30	16.04	26.34	56.00	-29.66	QP	P
10	0.58	10.30	7.54	17.84	46.00	-28.16	Average	P
11	28.14	11.02	25.00	36.02	60.00	-23.98	QP	P
12	28.14	11.02	17.78	28.80	50.00	-21.20	Average	P



4.4.2 Conducted Emission for Telecommunication Port Test Data

Not Applicable.



5. Test of Radiated Emission

5.1. Test Limit

The EUT shall meet the limits of below Table when measured at the measuring distance R in accordance with the methods described in European Standard EN 55032. If the reading on the measuring receiver shows fluctuations close to the limit, the reading shall be observed for at least 15 s at each measurement frequency; the highest reading shall be recorded, with the exception of any brief isolated high reading, which shall be ignored.

Required highest frequency for radiated measurement

Highest internal frequency (F _x)	Highest measured frequency
F _x ≤ 108 MHz	1 GHz
108 MHz < F _x ≤ 500 MHz	2 GHz
500 MHz < F _x ≤ 1 GHz	5 GHz
F _x > 1 GHz	5 x F _x up to a maximum of 6 GHz

NOTE 1 For FM and TV broadcast receivers, F_x is determined from the highest frequency generated or used excluding the local oscillator and tuned frequencies.
 NOTE 2 F_x is defined in 3.1.18.
 NOTE 3 For outdoor units of home satellite receiving systems highest measured frequency shall be 18GHz.

Where the F_x is unknown, the radiated emission measurements shall be performed up to 6 GHz.

Requirements for radiated emissions at frequencies up to 1 GHz for Class A equipment

Table clause	Frequency range MHz	Measurement		Class A limits dB(μV/m)
		Distance m	Detector type / bandwidth	OATS / SAC (see Table A.1)
A2.1	30 – 230	10	Quasi Peak / 120 kHz	40
	230 – 1 000			47
A2.2	30 – 230	3		50
	230 – 1 000			57

Apply only A2.1 or A2.2 across the entire frequency range.

Requirements for radiated emissions at frequencies above 1 GHz for Class A equipment

Table clause	Frequency range MHz	Measurement		Class A limits dB(μV/m)
		Distance m	Detector type / bandwidth	FSOATS (see Table A.1)
A3.1	1 000 –6 000	3	Average / 1 MHz	60
A3.2	1 000 –6 000		Peak / 1 MHz	80

Apply A3.1 and A3.2 across the frequency range from 1000 MHz to the highest required frequency of measurement derived from Table 1.



**Requirements for radiated emissions at frequencies up to 1 GHz
for Class B equipment**

Table clause	Frequency range MHz	Measurement		Class B limits dB(μ V/m)
		Distance m	Detector type / bandwidth	OATS / SAC (see Table A.1)
A4.1	30 – 230	10	Quasi Peak / 120 kHz	30
	230 – 1 000			37
A4.2	30 – 230	3		40
	230 – 1 000			47

Apply only table clause A4.1 or A4.2 across the entire frequency range.
These requirements are not applicable to the local oscillator and harmonics frequencies of equipment covered by Table A.6.

**Requirements for radiated emissions at frequencies above 1 GHz
for Class B equipment**

Table clause	Frequency range MHz	Measurement		Class B limits dB(μ V/m)
		Distance m	Detector type / bandwidth	FSOATS (see Table A.1)
A5.1	1 000 –6 000	3	Average / 1 MHz	54
A5.2	1 000 –6 000		Peak / 1 MHz	74

Apply A5.1 and A5.2 across the frequency range from 1000 MHz to the highest required frequency of measurement derived from Table 1.

Requirements for radiated emissions from FM receivers

Table clause	Frequency range MHz	Measurement		Class B limit dB(μ V/m)		
		Distance m	Detector type / bandwidth	Fundamental OATS/SAC (see Table A.1)	Harmonics OATS/SAC (see Table A.1)	
A6.1	30 – 230	10	Quasi peak / 120 kHz	50	42	
	230 – 300				42	
	300 – 1 000				46	
A6.2	30 – 230	3		Quasi peak / 120 kHz	60	52
	230 – 300					52
	300 – 1 000					56

Apply only A.6.1 or A.6.2 across the entire frequency range.
These relaxed limits apply only to emissions at the fundamental and harmonic frequencies of the LO. Signals at all other frequencies shall be compliant with the limits given in Table A.4.



Requirements for conducted differential voltage emissions from Class B equipment

Table clause	Frequency Range MHz	Detector type / bandwidth	Class B limits dB(μ V) 75Ω			Applicability
			Other	Local Oscillator Fundamental	Local Oscillator Harmonics	
A13.1	30 - 950	For frequencies ≤ 1 GHz	46	46	46	See ^a
	950 – 2 150		46	54	54	
A13.2	950 – 2 150	Quasi Peak / 120 kHz	46	54	54	See ^b
A13.3	30 – 300		46	54	50	See ^c
	300 – 1 000				52	
A13.4	30 - 300		For frequencies ≥ 1 GHz	46	66	59
	300 – 1 000	52				
A13.5	30 - 950	Peak / 1 MHz	46	76	46	See ^e
	950 – 2 150			n/a	54	

a Television receivers (analogue or digital), video recorders and PC TV broadcast receiver tuner cards working in channels between 30 MHz and 1 GHz, and digital audio receivers.
b Tuner units (not the LNB) for satellite signal reception.
c Frequency modulation audio receivers and PC tuner cards.
d Frequency modulation car radios.
e Applicable to EUTs with RF modulator output ports (for example DVD equipment, video recorders, camcorders and decoders etc.) designed to connect to TV broadcast receiver tuner ports. Limits specified for the LO are for the RF modulator carrier signal and harmonics. The term ‘other’ refers to all emissions other than the fundamental and the harmonics of the LO. The measurement shall cover the entire frequency range. The EUT shall be tuned in accordance with Table B.3 and clause C.4.2.1.

5.2. Test Procedures

- a. The EUT was placed on a rotatable table top 0.8 meter above ground.
- b. The EUT was set 3/10 meters from the interference receiving antenna which was mounted on the top of a variable height antenna tower.
- c. The table was rotated 360 degrees to determine the position of the highest radiation.
- d. The antenna is a half wave dipole and its height is varied between one meter and four meters above ground to find the maximum value of the field strength both horizontal polarization and vertical polarization of the antenna are set to make the measurement.
- e. For each suspected emission the EUT was arranged to its worst case and then tune the antenna tower (from 1 M to 4 M) and turn table (from 0 degree to 360 degrees) to find the maximum reading.
- f. Set the test-receiver system to Peak Detect Function and specified bandwidth with Maximum Hold Mode.
- g. If the emission level of the EUT in peak mode was 6 dB lower than the limit specified, then testing will be stopped and peak values of EUT will be reported, otherwise, the emissions which do not have 6 dB margin will be repeated one by one using the quasi-peak method and reported.

5.3. Typical Test Setup

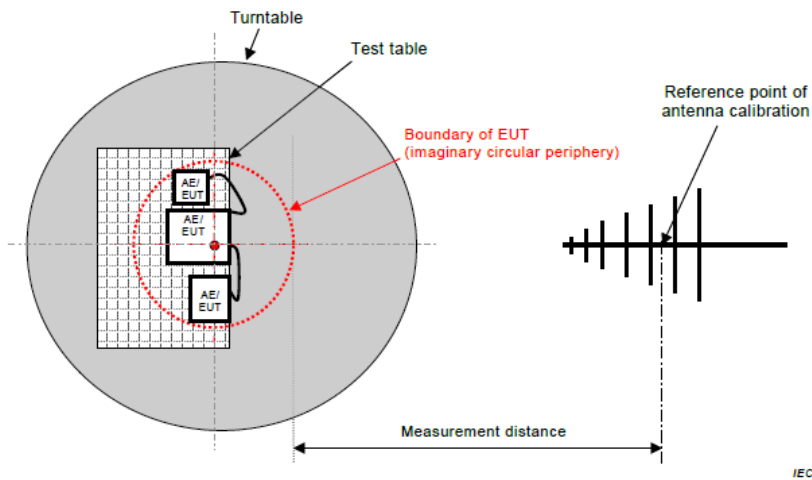
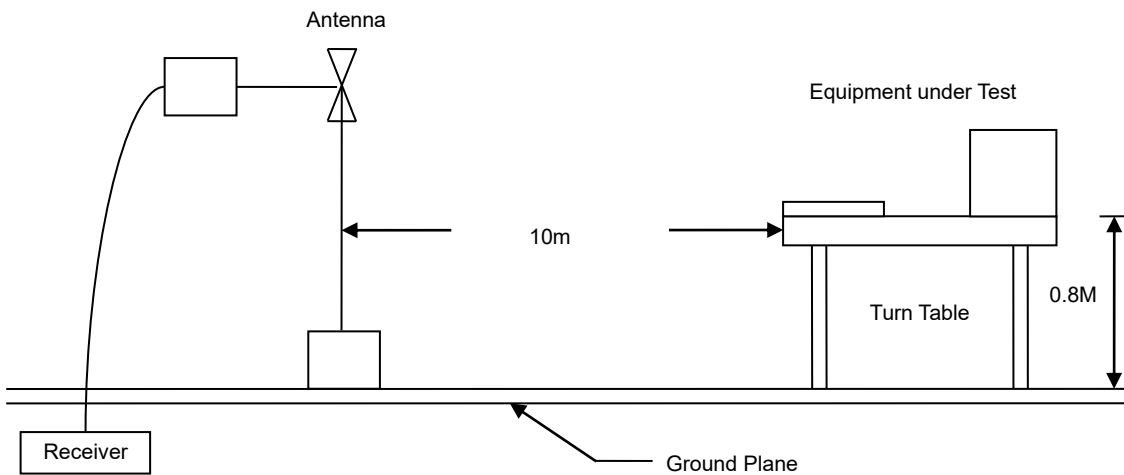
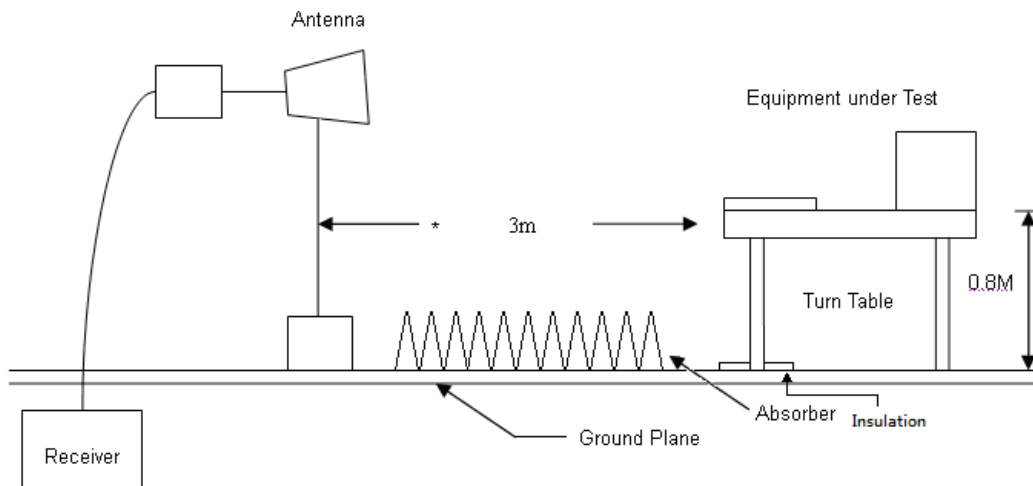

Figure C.1 – Measurement distance

Below 1GHz Test Setup



Above 1GHz Test Setup





5.4. Test Result and Data (30MHz ~ 1GHz)

Test Mode:	Test Mode 1	Test Engineer	Amos
Power:	AC 230V/50Hz	Phase:	VERTICAL
Temperature:	24°C	Humidity:	44%
EUT:	AGP277QKDC		

Note: Level = Reading + Factor
 Margin = Level – Limit
 Factor = Antenna Factor + Cable Loss – Amplifier Factor

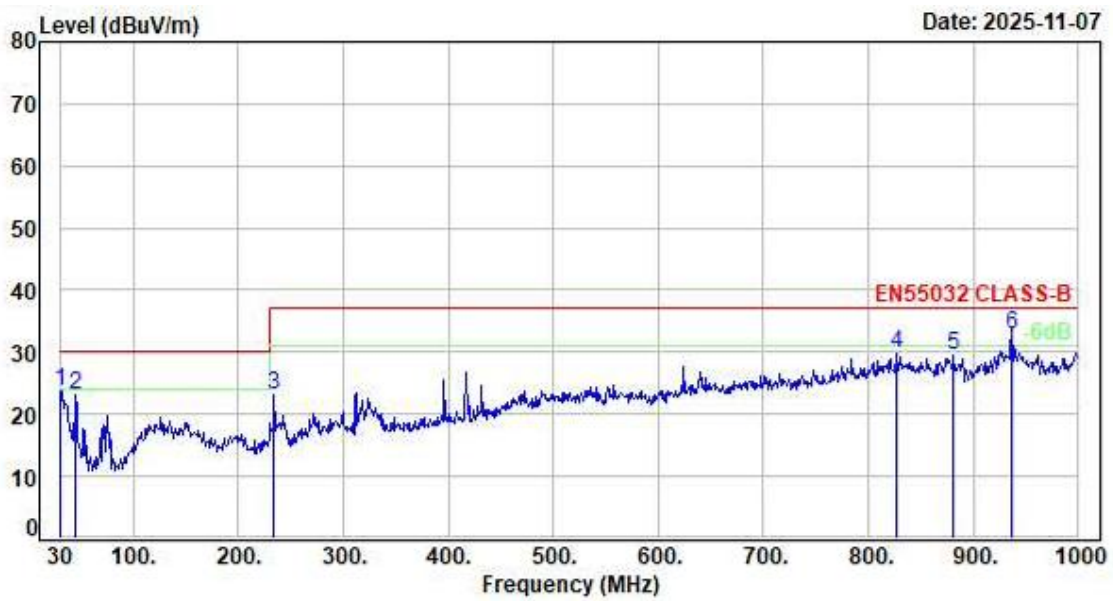

No.	Frequency (MHz)	Factor (dB/m)	Reading (dBUV)	Level (dBUV/m)	Limit (dBUV/m)	Margin (dB)	Detector	Height (cm)	Azimuth (deg)	P/F
1	30.00	-4.25	28.06	23.81	30.00	-6.19	Peak	300	72	P
2	45.52	-14.21	37.36	23.15	30.00	-6.85	Peak	400	0	P
3	233.70	-12.67	35.69	23.02	37.00	-13.98	Peak	400	0	P
4	827.34	0.00	29.94	29.94	37.00	-7.06	Peak	400	210	P
5	881.66	0.66	28.89	29.55	37.00	-7.45	Peak	300	360	P
6	936.95	1.24	31.70	32.94	37.00	-4.06	QP	200	127	P



Test Mode:	Test Mode 1	Test Engineer	Amos
Power:	AC 230V/50Hz	Phase:	HORIZONTAL
Temperature:	24°C	Humidity:	44%
EUT:	AGP277QKDC		

Note: Level = Reading + Factor
 Margin = Level – Limit
 Factor = Antenna Factor + Cable Loss – Amplifier Factor

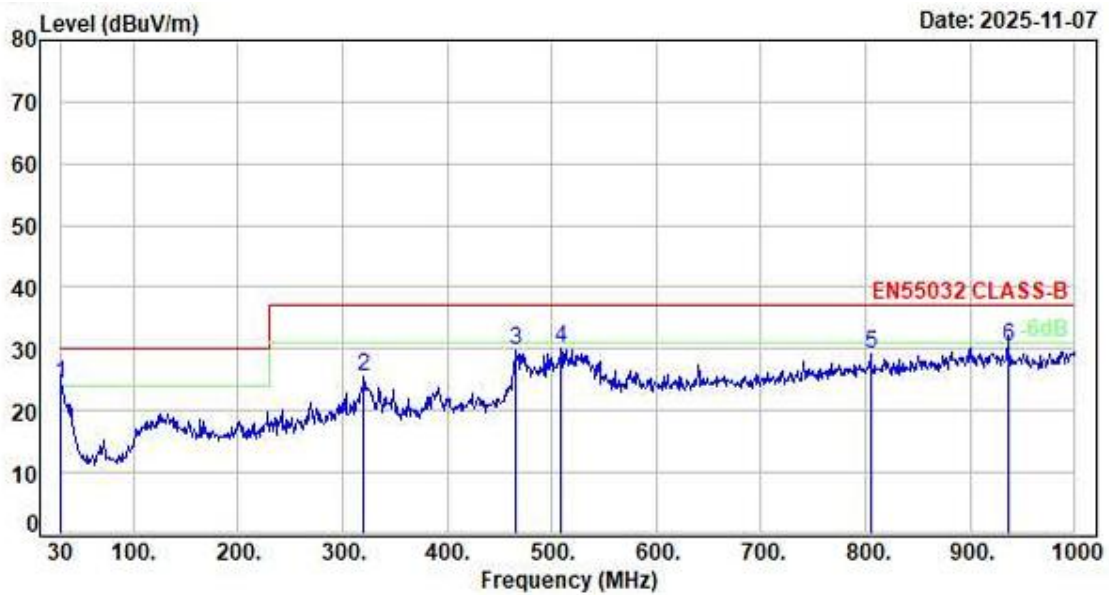

No.	Frequency (MHz)	Factor (dB/m)	Reading (dBUV)	Level (dBUV/m)	Limit (dBUV/m)	Margin (dB)	Detector	Height (cm)	Azimuth (deg)	P/F
1	30.00	-3.42	27.90	24.48	30.00	-5.52	QP	300	181	P
2	320.03	-8.76	34.45	25.69	37.00	-11.31	Peak	200	311	P
3	465.53	-5.00	34.74	29.74	37.00	-7.26	Peak	100	351	P
4	509.18	-4.28	34.37	30.09	37.00	-6.91	Peak	400	337	P
5	805.03	0.03	29.02	29.05	37.00	-7.95	Peak	100	46	P
6	935.98	1.63	28.90	30.53	37.00	-6.47	QP	200	58	P



5.5. Test Result and Data (Above 1GHz)

Test Mode:	Test Mode1	Test Engineer	Amos
Power:	AC 230V/50Hz	Phase:	VERTICAL
Temperature:	23°C	Humidity:	56%
EUT:	AGP277QKDC		

Note: Level = Reading + Factor
 Margin = Level – Limit
 Factor = Antenna Factor + Cable Loss – Amplifier Factor

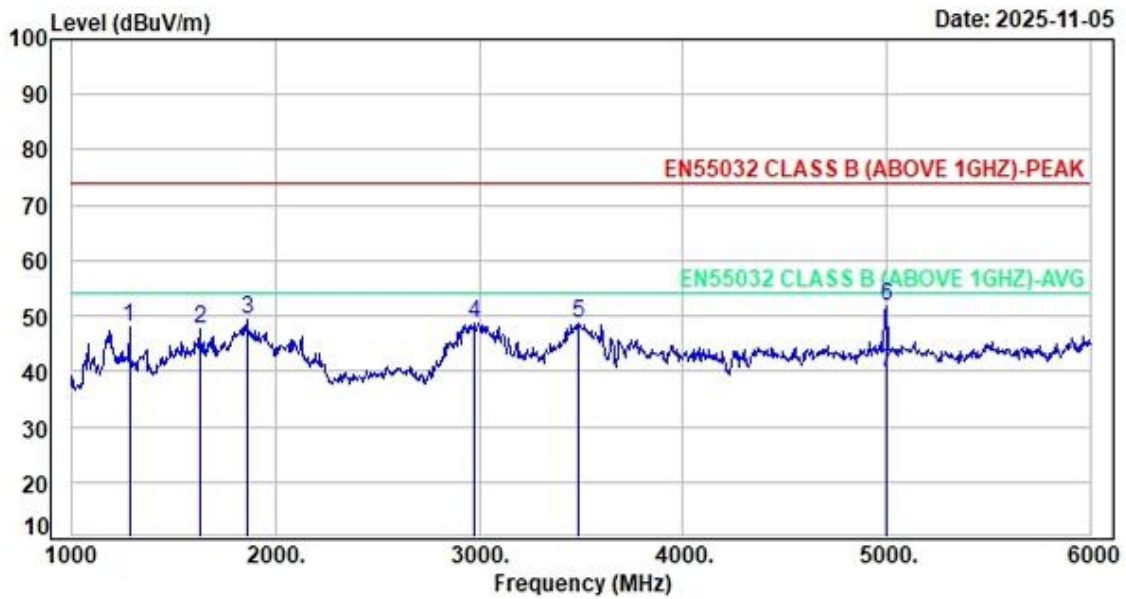

No.	Frequency (MHz)	Factor (dB/m)	Reading (dBUV)	Level (dBUV/m)	Limit (dBUV/m)	Margin (dB)	Detector	Height (cm)	Azimuth (deg)	P/F
1	1285.00	-16.89	64.71	47.82	74.00	-26.18	Peak	200	85	P
2	1630.00	-16.04	63.59	47.55	74.00	-26.45	Peak	100	172	P
3	1860.00	-15.83	65.30	49.47	74.00	-24.53	Peak	200	97	P
4	2980.00	-13.06	61.72	48.66	74.00	-25.34	Peak	100	163	P
5	3485.00	-11.75	60.45	48.70	74.00	-25.30	Peak	100	224	P
6	4995.00	-6.11	58.03	51.92	74.00	-22.08	Peak	100	7	P
7	4995.00	-6.11	45.77	39.66	54.00	-14.34	Average	100	7	P



Test Mode:	Test Mode1	Test Engineer	Amos
Power:	AC 230V/50Hz	Phase:	HORIZONTAL
Temperature:	23°C	Humidity:	56%
EUT:	AGP277QKDC		

Note: Level = Reading + Factor
 Margin = Level – Limit
 Factor = Antenna Factor + Cable Loss – Amplifier Factor

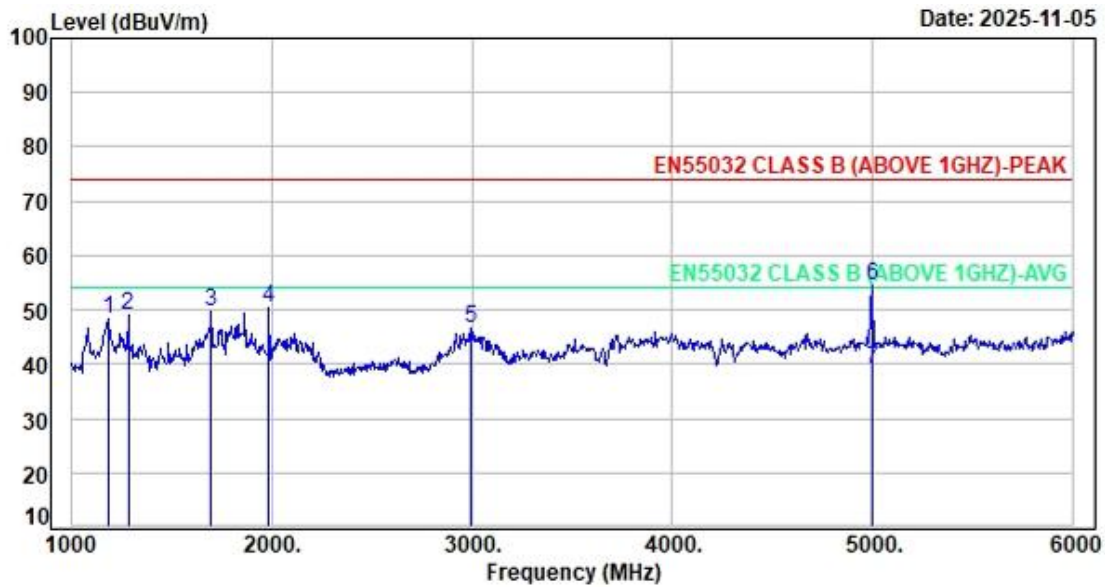

No.	Frequency (MHz)	Factor (dB/m)	Reading (dBuV)	Level (dBuV/m)	Limit (dBuV/m)	Margin (dB)	Detector	Height (cm)	Azimuth (deg)	P/F
1	1185.00	-17.08	65.39	48.31	74.00	-25.69	Peak	100	311	P
2	1285.00	-16.89	65.91	49.02	74.00	-24.98	Peak	100	286	P
3	1700.00	-15.97	65.75	49.78	74.00	-24.22	Peak	100	7	P
4	1985.00	-15.51	65.99	50.48	74.00	-23.52	Peak	200	164	P
5	2995.00	-12.95	59.61	46.66	74.00	-27.34	Peak	200	155	P
6	4995.00	-6.11	60.74	54.63	74.00	-19.37	Peak	100	85	P
7	4995.00	-6.11	45.30	39.19	54.00	-14.81	Average	100	85	P



6. Harmonics Test

6.1. Limits of Harmonics Current Measurement

Limits for Class A equipment

Harmonics Order n	Max. permissible harmonics current A	Harmonics Order n	Max. permissible harmonics current A
Odd harmonics		Even harmonics	
3	2.30	2	1.08
5	1.14	4	0.43
7	0.77	6	0.30
9	0.40	8<=n<=40	0.23x8/n
11	0.33		
13	0.21		
15<=n<=39	0.15x15/n		

(b) Limits for Class B equipment

For Class B equipment, the harmonics of the input current shall not exceed the values given in Table that is the limit of Class A multiplied by a factor of 1,5.

(c) Limits for Class C equipment

Harmonics Order n	Maximum permissible harmonic current expressed as a percentage of the input current at the fundamental frequency %
2	2
3	$30 \cdot \lambda^*$
5	10
7	7
9	5
11<n<39 (odd harmonics only)	3

* λ is the circuit power factor

(d) Limits for Class D equipment

Harmonics Order n	Maximum permissible harmonic current per watt mA/W	Maximum permissible harmonic current A
3	3.4	2.30
5	1.9	1.14
7	1.0	0.77
9	0.5	0.40
11	0.35	0.33
11 < n < 39 (odd harmonics only)	3.85/n	See limit of Class A

NOTE: The above limits for all equipment except for lighting equipment having an active input power > 75 W and no limits apply for equipment with an active input power up to and including 75 W.



6.2. Test Result and Data

Basic Standard	:	EN IEC 61000-3-2
Final Test Result	:	PASS
Temperature	:	24°C
Humidity	:	50%
Atmospheric Pressure	:	1010hPa
Test Date	:	2025.11.10
Test Mode 1	:	Full system (HDMI1 mode 2560*1440@540Hz +USB-B:KVM) Signal from PC with +USB*3 to U Disk+USB-C to Load(20V/3.25A)+Built-in speaker For 230V(Horizontal)



Harmonics – Class-D per IEC 61000-3-2:2018/AMD1:2020(Run time)

EUT: AGP277QKDC

Tested by: Lan

Test category: Class-D (European limits)

Test Margin: 100

Test date: 2025/11/10

Start time: 14:26:14

End time: 14:29:25

Test duration (min): 3

Data file name: H-000222.cts_data

Test Result: N/L

Source qualification: Normal

Current & voltage waveforms

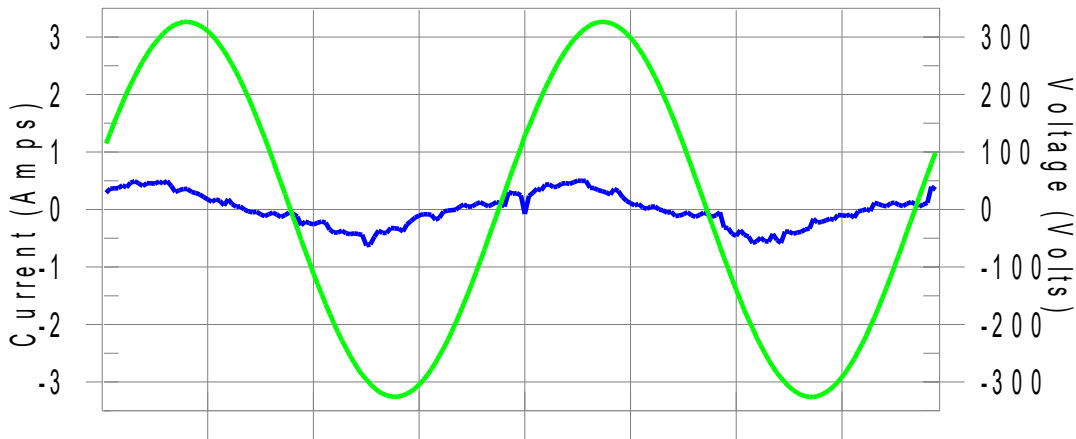

Harmonics and Class D limit line

European Limits

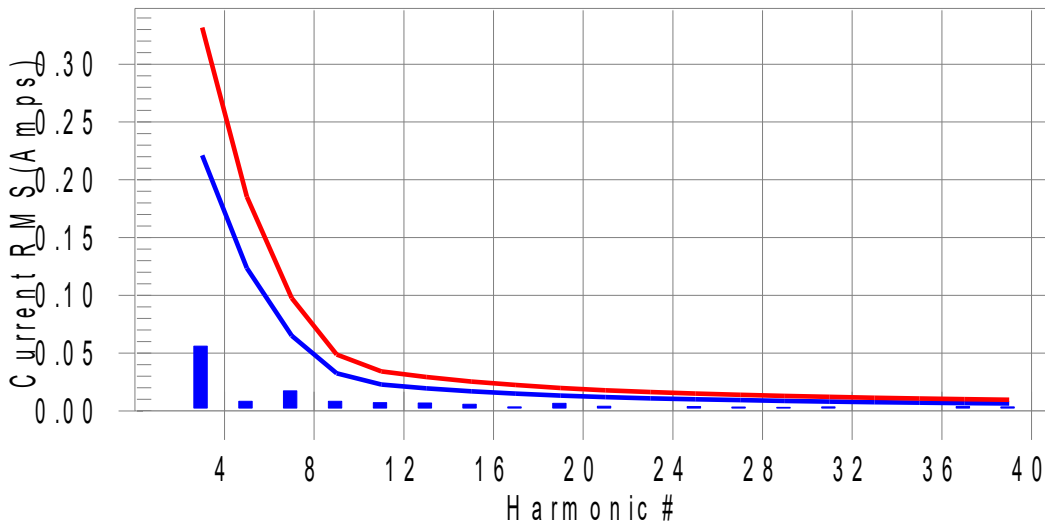

Test result: N/L Worst harmonics H0-0.0% of 150% limit, H0-0% of 100% limit



Current Test Result Summary (Run time)

EUT: AGP277QKDC Tested by: Lan
Test category: Class-D (European limits) Test Margin: 100
Test date: 2025/11/10 Start time: 14:26:14 End time: 14:29:25
Test duration (min): 3 Data file name: H-000222.cts_data
Test Result: N/L Source qualification: Normal
THC(A): 0.062 I-THD(%): 19.1 POHC(A): 0.010 POHC Limit(A): 0.028

Highest parameter values during test:

V_RMS (Volts): 230.73 Frequency(Hz): 50.00
I_Peak (Amps): 2.321 I_RMS (Amps): 0.336
I_Fund (Amps): 0.326 Crest Factor: 7.872
Power (Watts): 65.0 Power Factor: 0.844

Table with 8 columns: Harm#, Harms(avg), 100%Limit, %of Limit, Harms(max), 150%Limit, %of Limit, Status. Rows 2-40 showing various harmonic measurements and their compliance status.

Note: The EUT power level is below 75.0 Watts and therefore has no defined limits



Voltage Source Verification Data (Run time)

EUT: AGP277QKDC
 Test category: Class-D (European limits)
 Test date: 2025/11/10
 Test duration (min): 3
 Test Result: N/L

Tested by: Lan
 Test Margin: 100
 End time: 14:29:25
 Start time: 14:26:14
 Data file name: H-000222.cts_data
 Source qualification: Normal

Highest parameter values during test:

Voltage (Vrms): 230.73
 I_Peak (Amps): 2.321
 I_Fund (Amps): 0.326
 Power (Watts): 65.0

Frequency(Hz): 50.00
 I_RMS (Amps): 0.336
 Crest Factor: 7.872
 Power Factor: 0.844

Harm#	Harmonics V-rms	Limit V-rms	% of Limit	Status
2	0.093	0.461	20.15	OK
3	0.400	2.076	19.29	OK
4	0.053	0.461	11.39	OK
5	0.026	0.923	2.80	OK
6	0.029	0.461	6.34	OK
7	0.052	0.692	7.57	OK
8	0.026	0.461	5.64	OK
9	0.043	0.461	9.22	OK
10	0.021	0.461	4.51	OK
11	0.020	0.231	8.54	OK
12	0.015	0.231	6.30	OK
13	0.016	0.231	6.73	OK
14	0.013	0.231	5.57	OK
15	0.017	0.231	7.21	OK
16	0.014	0.231	6.03	OK
17	0.013	0.231	5.54	OK
18	0.016	0.231	6.96	OK
19	0.013	0.231	5.81	OK
20	0.015	0.231	6.55	OK
21	0.011	0.231	4.85	OK
22	0.009	0.231	3.72	OK
23	0.009	0.231	4.05	OK
24	0.008	0.231	3.51	OK
25	0.011	0.231	4.67	OK
26	0.009	0.231	4.02	OK
27	0.011	0.231	4.61	OK
28	0.008	0.231	3.28	OK
29	0.008	0.231	3.46	OK
30	0.008	0.231	3.28	OK
31	0.011	0.231	4.61	OK
32	0.007	0.231	2.87	OK
33	0.009	0.231	3.75	OK
34	0.007	0.231	3.17	OK
35	0.009	0.231	3.87	OK
36	0.007	0.231	2.98	OK
37	0.011	0.231	4.67	OK
38	0.007	0.231	3.20	OK
39	0.011	0.231	4.62	OK
40	0.008	0.231	3.61	OK



7. Voltage Fluctuations Test

7.1. Test Procedure

The equipment shall be tested under the conditions of **Clause 5**.

The total impedance of the test circuit, excluding the appliance under test, but including the internal impedance of the supply source, shall be equal to the reference impedance.

The stability and tolerance of the reference impedance shall be adequate to ensure that the overall accuracy of $\pm 8\%$ is achieved during the whole assessment procedure.

7.2. Test Result and Data

Basic Standard	:	EN 61000-3-3
Final Test Result	:	PASS
Temperature	:	24°C
Humidity	:	50%
Atmospheric Pressure	:	1010hPa
Test Date	:	2025.11.10
Test Mode 1	:	Full system (HDMI1 mode 2560*1440@540Hz +USB-B:KVM) Signal from PC with +USB*3 to U Disk+USB-C to Load(20V/3.25A)+Built-in speaker For 230V(Horizontal)



Flicker Test Summary per IEC61000-3-3:2013/AMD1:2017 (Run time)

EUT: AGP277QKDC

Tested by: Lan

Test category: All parameters (European limits)

Test Margin: 100

Test date: 2025/11/10

Start time: 13:18:16

End time: 13:28:43

Test duration (min): 10

Data file name: F-000220.cts_data

Test Result: Pass

Status: Test Completed

Pst_i and limit line

European Limits



Plt and limit line

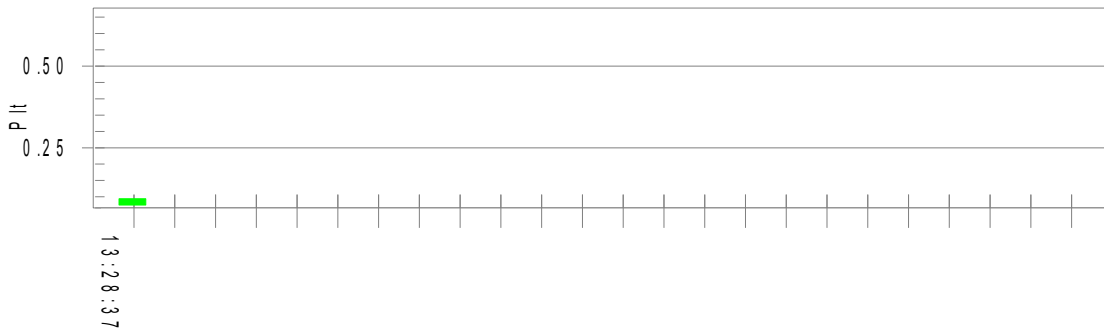

Parameter values recorded during the test:

Vrms at the end of test (Volt): 230.51

Highest dt (%):

T-max (mS): 0

Highest dc (%): 0.00

Highest dmax (%): 0.00

Highest Pst (10 min. period): 0.215

Highest Plt (2 hr. period): 0.094

Test limit (%):

Test limit (mS): 500.0 Pass

Test limit (%): 3.30 Pass

Test limit (%): 4.00 Pass

Test limit: 1.000 Pass

Test limit: 0.650 Pass



8. Electrostatic Discharge Immunity Test

8.1. Test Procedure

- a. In the case of air discharge testing the climatic conditions shall be within the following ranges:
- ambient temperature: 15°C to 35°C;
 - relative humidity : 30% to 60%;
 - atmospheric pressure: 86 KPa (860 mbar) to 106 KPa (1060 mbar).
- b. Test programs and software shall be chosen so as to exercise all normal modes of operation of the EUT. The use of special exercising software is encouraged, but permitted only where it can be shown that the EUT is being comprehensively exercised.
- c. The test voltage shall be increased from the minimum to the selected test severity level, in order to determine any threshold of failure. The final severity level should not exceed the product specification value in order to avoid damage to the equipment.
- d. The test shall be performed with both air discharge and contact discharge. On reselected points at least 10 single discharges (in the most sensitive polarity) shall be applied on air discharge. On reselected points at least 25 single discharges (in the most sensitive polarity) shall be applied on contact discharge.
- e. For the time interval between successive single discharges an initial value of one second is recommended. Longer intervals may be necessary to determine whether a system failure has occurred.
- f. In the case of contact discharges, the tip of the discharge electrode shall touch the EUT before the discharge switch is operated.
- g. In the case of painted surface covering a conducting substrate, the following procedure shall be adopted:
- If the coating is not declared to be an insulating coating by the equipment manufacturer, then the pointed tip of the generator shall penetrate the coating so as to make contact with the conducting substrate.
 - Coating declared as insulating by the manufacturer shall only be submitted to the air discharge.
 - The contact discharge test shall not be applied to such surfaces.
- h. In the case of air discharges, the round discharge tip of the discharge electrode shall be approached as fast as possible (without causing mechanical damage) to touch the EUT. After each discharge, the ESD generator (discharge electrode) shall be removed from the EUT. The generator is then retriggered for a new single discharge. This procedure shall be repeated until the discharges are completed. In the case of an air discharge test, the discharge switch, which is used for contact discharge, shall be closed.

8.2. Test Setup for Tests Performed in Laboratory

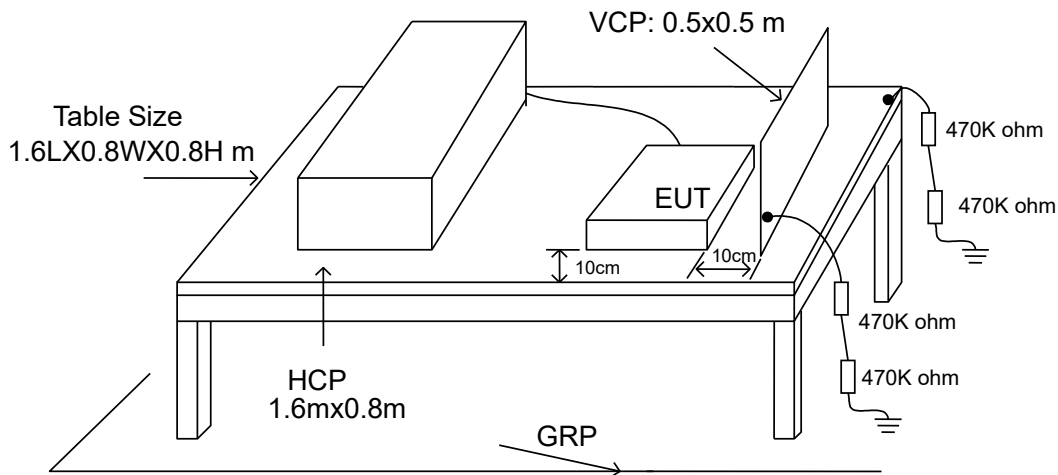

The test setup consists of the test generator, EUT and auxiliary instrumentation necessary to perform DIRECT and INDIRECT application of discharges to the EUT as applicable, in the follow manner:

- a. Contact Discharge to the conductive surfaces and to coupling plane;
- b. Air Discharge at insulating surfaces.

The preferred test method is that of type tests performed in laboratories and the only accepted method of demonstrating conformance with this standard. The EUT was arranged as closely as possible to arrangement in final installed conditions.

A ground reference plane was provided on the floor of the test site. It was a metallic sheet (copper or aluminum) of 0.25 mm, minimum thickness; other metallic may be used but they shall have at least 0.65 mm thickness. In the CerpPASS Technology Corp., we provided 1 mm thickness stainless steel ground reference plane. The minimum size of the ground reference plane is 2.5 m x 2.5 m, the exact size depending on the dimensions of the EUT. It was connected to the protective grounding system.

The EUT was arranged and connected according to its functional requirements. A distance of 1m minimum was provided between the EUT and the wall of the lab. and any other metallic structure. In cases where this length exceeds the length necessary to apply the discharges to the selected points, the excess length shall, where possible, be placed non-inductively off the ground reference plane and shall not come closer than 0.2m to other conductive parts in the test setup.

Where the EUT is installed on a metal table, the table was connected to the reference plane via a cable with a 470k ohm resistor located at each end, to prevent a build-up of charge. The test setup was consist a wooden table, 0.8m high, standing on the ground reference plane. A HCP, 1.6 m x 0.8 m, was placed on the table. The EUT and cables was isolated from the HCP by an insulating support 0.5 mm thick. The VCP size, 0.5 m x 0.5 m.

8.3. Test Severity Levels

Contact Discharge	Air Discharge
-------------------	---------------



Level	Test Voltage (KV) of Contact discharge	Level	Test Voltage (KV) of Air Discharge
1	±2	1	±2
2	±4	2	±4
3	±6	3	±8
4	±8	4	±15
X	Specified	X	Specified

Remark: "X" is an open level.



8.4. Test Result and Data

Final Test Result : **PASS**
 Required performance criteria : B
 Basic Standard : IEC 61000-4-2
 Product Standard : EN 55035
 Model No. : AGP277QKDC
 Test Voltage : ±2 / ±4 / ±8 kV for air discharge,
 : ±2 / ±4 kV for contact discharge
 Temperature : 24 °C
 Relative Humidity : 50%
 Atmospheric Pressure : 1010hPa
 Test Date : 2025.11.10
 Test Mode 1 : Full system (HDMI1 mode 2560*1440@540Hz
 : +USB-B:KVM) Signal from PC with +USB*3 to U
 : Disk+USB-C to Load(20V/3.25A)+Built-in speaker For

	Contact Discharge								Air Discharge							
	10 times / each								10 times / each							
Voltage	2 kV		4 kV		6 kV		8 kV		2 kV		4 kV		8 kV		15kV	
Point\Polarity	+	-	+	-	+	-	+	-	+	-	+	-	+	-	+	-
VCP Front	A	A	A	A	---	---	---	---	---	---	---	---	---	---	---	---
VCP Right	A	A	A	A	---	---	---	---	---	---	---	---	---	---	---	---
VCP Left	A	A	A	A	---	---	---	---	---	---	---	---	---	---	---	---
VCP Rear	A	A	A	A	---	---	---	---	---	---	---	---	---	---	---	---
HCP Front	A	A	A	A	---	---	---	---	---	---	---	---	---	---	---	---
HCP Right	A	A	A	A	---	---	---	---	---	---	---	---	---	---	---	---
HCP Left	A	A	A	A	---	---	---	---	---	---	---	---	---	---	---	---
HCP Rear	A	A	A	A	---	---	---	---	---	---	---	---	---	---	---	---
Screw	A	A	A	A	---	---	---	---	---	---	---	---	---	---	---	---
Case	---	---	---	---	---	---	---	---	A	A	A	A	A	A	---	---
Panel	---	---	---	---	---	---	---	---	A	A	A	A	A	A	---	---
HDMI1 Port	A	A	A	A	---	---	---	---	A	A	A	A	A	A	---	---
DP Port	A	A	A	A	---	---	---	---	A	A	A	A	A	A	---	---
HDMI2 Port	A	A	A	A	---	---	---	---	A	A	A	A	A	A	---	---
Earphone Port	---	---	---	---	---	---	---	---	A	A	A	A	A	A	---	---
Type-C Port	A	A	A	A	---	---	---	---	A	A	A	A	A	A	---	---
USB-B Port	A	A	A	A	---	---	---	---	A	A	A	A	A	A	---	---
USB Port*3	A	A	A	A	---	---	---	---	A	A	A	A	A	A	---	---



AC Power Port	---	---	---	---	---	---	---	---	A	A	A	A	A	A	---	---
Button	---	---	---	---	---	---	---	---	A	A	A	A	A	A	---	---
LED Light	---	---	---	---	---	---	---	---	A	A	A	A	A	A	---	---

Note: "A" means the EUT function is normal working during the test.

Test engineer: Nunny



9. Radio Frequency electromagnetic field immunity test

9.1. Test Procedure

- a. The equipment to be tested is placed in the center of the enclosure on a wooden table. The equipment is then connected to power and signal leads according to pertinent installation instructions.
- b. The antenna which is enabling the complete frequency range of 80-6000 MHz is placed 3m away from the equipment. The required field strength is determined by placing the field strength meter(s) on top of or directly alongside the equipment under test and monitoring the field strength meter via a remote field strength indicator outside the enclosure while adjusting the continuous-wave to the applicable antennae.
- c. The test is normally performed with the antenna facing the most sensitive side of the EUT. The polarization of the field generated by the bucolical antenna necessitates testing each position twice, once with the antenna positioned vertically and again with the antenna positioned horizontally. The circular polarization of the field from the log-spiral antenna makes a change of position of the antenna unnecessary.
- d. At each of the above conditions, the frequency range is swept 80-6000 MHz, pausing to adjust the R.F. signal level or to switch oscillators and antenna. The rate of sweep is in the order of 1.5×10^{-3} decades/s. The sensitive frequencies or frequencies of dominant interest may be discretely analyzed.

9.2. Test Severity Levels

Frequency Band : 80-5000 MHz	
Level	Test field strength (V/m)
1	1
2	3
3	10
X	Specified
Remark: "X" is an open class.	

Audio port Reference level					
Type of immunity test	Frequency Range MHZ	Acoustic or electrical Interference ratio	Equivalent direct measurement		
			dB(SPL)	Digital dBm	Analogue dBm
Radiated	80 to 1000	0db	75	-30	-30
L0	Input the appropriate signal to the EUT, adjust the EUT output to achieve "Reference level", and record the set value.				
L1	When the L0 is set, the EUT output is closed to ensure that the impedance of its input is kept unchanged and the RF test is started. At this time the value of the record is L1, and the corresponding L1 changes are recorded according to the test frequency.				



9.3. Test Result and Data

Final Test Result : **PASS**
 Required performance criteria : A
 Basic Standard : IEC 61000-4-3
 Model No. : AGP277QKDC
 Product Standard : EN 55035
 Frequency Range : 80~1000, 1800, 2600, 3500, 5000MHz
 Temperature : 24°C
 Relative Humidity : 50%
 Atmospheric Pressure : 1010hPa
 Test Date : 2025.11.10
 Test Mode 1 : Full system (HDMI1 mode 2560*1440@540Hz +USB-B:KVM) Signal from PC with +USB*3 to U Disk+USB-C to Load(20V/3.25A)+Built-in speaker For 230V(Horizontal)

Modulation : AM 80% , 1KHz sine wave, Dwell time: 3 S				
Frequency Step Size : 1 % of preceding frequency value				
Frequency (MHz)	Antenna Polarization	face	Field strength (V/m)	Result
80~1000	Vertical	Front	3	A
80~1000	Vertical	Rear	3	A
80~1000	Vertical	Left	3	A
80~1000	Vertical	Right	3	A
80~1000	Horizontal	Front	3	A
80~1000	Horizontal	Rear	3	A
80~1000	Horizontal	Left	3	A
80~1000	Horizontal	Right	3	A

Modulation : AM 80% , 1KHz sine wave, Dwell time: 3 S				
Frequency Step Size : 1 % of preceding frequency value				
Frequency (MHz)	Antenna Polarization	face	Field strength (V/m)	Result
1800MHz ,2600MHz, 3500MHz, 5000MHz	Vertical	Front	3	A
1800MHz ,2600MHz, 3500MHz, 5000MHz	Vertical	Rear	3	A
1800MHz ,2600MHz, 3500MHz, 5000MHz	Vertical	Left	3	A
1800MHz ,2600MHz, 3500MHz, 5000MHz	Vertical	Right	3	A
1800MHz ,2600MHz, 3500MHz, 5000MHz	Horizontal	Front	3	A
1800MHz ,2600MHz, 3500MHz, 5000MHz	Horizontal	Rear	3	A
1800MHz ,2600MHz, 3500MHz, 5000MHz	Horizontal	Left	3	A
1800MHz ,2600MHz, 3500MHz, 5000MHz	Horizontal	Right	3	A

Note: "A" means the EUT function is normal working during the test.



Headset port test Result and Data

Modulation : AM 80% , 1KHz sine wave, Dwell time: 3 S					
Frequency Step Size : 1 % of preceding frequency value					
L0 : 26%Reference level : -20 dBmBase Noise : -76 dBm					
Frequency (MHz)	Antenna Polarization	Face	L1- L0 (SPL)	Reference level (SPL)	Result
430	Vertical	Front	-33	-20	A
629	Vertical	Rear	-31	-20	A
187	Vertical	Left	-34	-20	A
263	Vertical	Right	-35	-20	A
338	Horizontal	Front	-33	-20	A
592	Horizontal	Rear	-34	-20	A
504	Horizontal	Left	-35	-20	A
487	Horizontal	Right	-32	-20	A

Speaker port test Result and Data

Modulation: AM 80%, 1KHz sine wave, Dwell time: 3 S					
Frequency Step Size: 1 % of preceding frequency value					
L0 : 26%Reference level : -20 dBmBase Noise : -76 dBm					
Frequency (MHz)	Antenna Polarization	Face	L1- L0 (SPL)	Reference level (SPL)	Result
456	Vertical	Front	-33	-20	A
347	Vertical	Rear	-34	-20	A
644	Vertical	Left	-32	-20	A
272	Vertical	Right	-33	-20	A
328	Horizontal	Front	-35	-20	A
573	Horizontal	Rear	-34	-20	A
303	Horizontal	Left	-32	-20	A
188	Horizontal	Right	-34	-20	A

Test engineer: Nunq



10. Electrical Fast Transient/ Burst Immunity Test

10.1. Test Procedure

- a. In order to minimize the effect of environmental parameters on test results, the climatic conditions when test is carrying out shall comply with the following requirements:
 - ambient temperature: 15°C to 35°C;
 - relative humidity : 45% to 75%;
 - Atmospheric pressure: 86 Kpa (860 mbar) to 106 Kpa (1060 mbar).
- b. In order to minimize the effect of environmental parameters on test results, the electromagnetic environment of the laboratory shall not influence the test results.
- c. The variety and diversity of equipment and systems to be tested make it difficult to establish general criteria for the evaluation of the effects of fast transients/bursts on equipment and systems.
- d. Test on Power Line:
 - The EFT/B-generator was located on the GRP.
For floor standing equipment 1,0 m
For table top equipment 0,5 m
 - The EFT/B-generator provides the ability to apply the test voltage in a non-symmetrical condition to the power supply input terminals of the EUT.
- e. Test on Communication Lines
 - The coupling clamp is composed of a clamp unit for housing the cable (length more than 3 m), and was placed on the GRP.
 - The coupling clamp provides the ability of coupling the fast transient/bursts to the cable under test.
- f. The test results may be classified on the basic of the operating conditions and the functional specification of the equipment under test, according to the following performance criteria :
 - Normal performance within the specification limits.
 - Temporary degradation or loss of function or performance which is self-recoverable.
 - Temporary degradation or loss of function or performance which requires operator intervention or system reset.
 - Degradation or loss of function which is not recoverable due to damage of equipment (components).

10.2. Test Severity Levels

The following test severity levels are recommended for the fast transient/burst test :

Open circuit output test voltage $\pm 10\%$		
Level	On Power Supply	On I/O signal, data and control line
1	0.5 KV	0.25 KV
2	1.0 KV	0.50 KV
3	2.0 KV	1.00 KV
4	4.0 KV	2.00 KV
X	Specified	Specified

Remark: " X " is an open level. The level is subject to negotiation between the user and manufacturer or is specified by the manufacturer.



10.3. Test Result and Data

Final Test Result : **PASS**

Required performance criteria : B

Basic Standard : IEC 61000-4-4

Product Standard : EN 55035

Model No. : AGP277QKDC

Test Voltage : On Power Supply -- ± 0.5 kV / ± 1.0 kV
On I/O signal, data and control line -- ± 0.5 kV

Temperature : 24°C

Relative Humidity : 49%

Atmospheric Pressure : 1010hPa

Test Date : 2025.11.10

Test Mode 1 : Full system (HDMI1 mode 2560*1440@540Hz +USB-B:KVM) Signal from PC with +USB*3 to U Disk+USB-C to Load(20V/3.25A)+Built-in speaker For 230V(Horizontal)

Pulse: 5/50 ns		5kHz:except for xDSL equipment			
Burst :15m/300ms		100kHz:Only for single lines of xDSL equipment			
Test time: 1 min/each condition					
Voltage/ Mode/ Polarity/ Result/ Phase		<u>0.5 kV</u>		<u>1.0 kV</u>	
		+	-	+	-
Power Line	L	---	---	A	A
	N	---	---	A	A
	L-N	---	---	A	A
	PE	---	---	A	A
	L-PE	---	---	A	A
	N-PE	---	---	A	A
	L-N-PE	---	---	A	A

Note: "A" means the EUT function is normal working during the test.

Test engineer: Nunny



11. Surge Immunity Test

11.1. Test Procedure

- a. Climatic conditions
The climatic conditions shall comply with the following requirements:
 - ambient temperature: 15 °C to 35 °C
 - relative humidity: 10 % to 75 %
 - atmospheric pressure: 86 kPa to 106 kPa (860 mbar to 1060 mbar)
- b. Electromagnetic conditions
the electromagnetic environment of the laboratory shall not influence the test results.
- c. The test shall be performed according the test plan that shall specify the test set-up with
 - generator and other equipment utilized;
 - test level (voltage/current);
 - generator source impedance;
 - internal or external generator trigger;
 - number of tests: at least five positive and five negative at the selected points;
 - repetition rate: maximum 1/min.
 - inputs and outputs to be tested;
 - representative operating conditions of the EUT;
 - sequence of application of the surge to the circuit;
 - phase angle in the case of AC. power supply;
 - actual installation conditions, for example:
 - AC: neutral earthed,
 - DC: (+) or (-) earthed to simulated the actual earthing conditions.
- d. If not otherwise specified the surges have to be applied synchronized to the voltage phase at the zero-crossing and the peak value of the AC. voltage wave (positive and negative).
- e. The surges have to be applied line to line and line(s) and earth. When testing line to earth, the test voltage has to be applied successively between each of the lines and earth, if there is no other specification.
- f. The test procedure shall also consider the non-linear current-voltage characteristics of the equipment under test. Therefore the test voltage has to be increased by steps up to the test level specified in the product standard or test plan.
- g. All lower levels including the selected test level shall be satisfied. For testing the secondary protection, the output voltage of the generator shall be increased up to the worst-case voltage breakdown level (let-through level) of the primary protection.
- h. If the actual operating signal sources are not available, that may be simulated. Under no circumstances may the test level exceed the product specification. The test shall be carried out according to a test plan.
- i. To find all critical points of the duty cycle of the equipment, a sufficient number of positive and negative test pulses shall be applied. For acceptance test previously unstressed equipment shall be used to the protection devices shall be replaced.

11.2. Test Severity Level

Level	Open-circuit test voltage (kV)	
	Line-to-line	Line-to-ground ^b
1	---	0.5
2	0.5	1.0
3	1.0	2.0
4	2.0	4.0
X ^a	Special	Special

^a "X" and be any level, above, below or in between the others. The level shall be specified in the dedicated equipment specification.

^b For symmetrical interconnection lines the test can be applied to multiple lines simultaneously with respect to ground, i.e. "lines to ground".



12. Conduction Disturbances induced by Radio-Frequency Fields

12.1. Test Procedure

- a. The EUT shall be operated within its intended climatic conditions. The temperature and relative humidity should be recorded.
- b. This test method test can be performed without using a sell shielded enclosure. This is because the disturbance levels applied and the geometry of the setups are not likely to radiated a high amount of energy, especially at the lower frequencies. If under certain circumstances the radiated energy is too high, a shielded enclosure has to be used.
- c. The test shall be performed with the test generator connected to each of the coupling and decoupling devices in turn while the other non-excited RF-input ports of the coupling devices are terminated by a 50ohm load resistor.
- d. The frequency range is swept from 150 KHz to 80 MHz, using the signal levels established during the setting process, and with the disturbance signal 80% amplitude modulated with a 1KHz sign wave, pausing to adjust the RF-signal level or to switch coupling devices as necessary. The rate of sweep shall no exceed 1.5×10^{-3} decades/s. Where the frequency is swept incrementally, the step size shall no exceed 1% of the start and thereafter 1% of the preceding frequency value.
- e. The dwell time at each frequency shall not be less than the time necessary for the EUT to be exercised, and able to respond. Sensitive frequencies e.g. clock frequency (ies) and harmonics or frequencies of dominant interest shall be analyzed separately.
- f. An alternative test procedure may be adopted, wherein the frequency range is swept incrementally, with a step size not exceeding 4% of the start and thereafter 4% of the preceding frequency value. The test level should be at least twice the value of the specified test level.
- g. In cases of dispute, the test procedure using a step size not exceeding 1% of the start and thereafter 1% of preceding frequency value shall take precedence.
- h. Attempts should be made to fully exercise the EUT during testing, and to fully interrogate all exercise modes selected for susceptibility.
- i. The use of special exercising programs is recommended.
- j. Testing shall be performed according to a Test Plan, which shall be included in the test report.
- k. It may be necessary to carry out some investigatory testing in order to establish some aspects of the test plan.

12.2. Test Severity Levels

Level	Voltage Level (e.m.f.)
1	1 V
2	3 V
3	10 V
x	Specified

NOTE - x is an open class. This level can be specified in the product specification.

Type of immunity test	Frequency Range MHZ	Acoustic or electrical Interference ratio	Equivalent direct measurement		
			Audio port Reference level		
			dB (SPL)	Digital dBm0	Analogue dBm
Conducted	0.15 to 30	-20dB	55	-50	-50
	30 to 80	-10dB	65	-40	-40

L0	Input the appropriate signal to the EUT, adjust the EUT output to achieve "Reference level", and record the set value.
L1	When the L0 is set, the EUT output is closed to ensure that the impedance of its input is kept unchanged and the RF test is started. At this time the value of the record is L1, and the corresponding L1 changes are recorded according to the test frequency.



12.3. Test Result and Data

Final Test Result : **PASS**
 Required performance criteria : A
 Basic Standard : IEC 61000-4-6
 Product Standard : EN 55035
 Model No. : AGP277QKDC
 Coupling mode : CDN-(M2+M3) for AC power ports
 EM-Clamp for signal ports
 Temperature : 24 °C
 Relative Humidity : 49%
 Atmospheric Pressure : 1010hPa
 Test Date : 2025.11.10
 Test Mode 1 : Full system (HDMI1 mode 2560*1440@540Hz
 +USB-B:KVM) Signal from PC with +USB*3 to U
 Disk+USB-C to Load(20V/3.25A)+Built-in speaker
 For 230V(Horizontal)

Frequency: 0.15~80MHz, Modulation: AM 80%, 1KHz sine wave, Dwell time: 3s Frequency Step Size: 1 % of preceding frequency value			
Frequency	Test mode	Voltage(V)	Result
0.15 ~ 10MHz,	Power(M3)	3	A
10 ~ 30MHz,		3-1	A
30 ~ 80MHz		1	A

Headset port test Procedure

Frequency : 0.15~80MHz, Modulation : AM 80%, 1KHz sine wave, Dwell time: 3S Frequency Step Size : 1 % of preceding frequency value				
L0 : 30%Reference level : -20 dBmBase noise : -78 dBm				
frequency range(MHz)	Test Mode	Frequency (MHz)	L1-L0 (SPL)	Result
0.15 ~ 10	AC means Power port	6.27	-32	A
10 ~ 30		23.53	-35	A
30 ~ 80		74.16	-33	A
0.15 ~ 10	Analogue/digital data ports	3.29	-32	A
10 ~ 30		18.38	-34	A
30 ~ 80		56.44	-35	A



Speaker port test Procedure

Frequency: 0.15~80MHz, Modulation: AM 80%,1KHz sine wave, Dwell time: 3S				
Frequency Step Size: 1 % of preceding frequency value				
L0 : 30%Reference level : -20 dBmBase noise : -78 dBm				
frequency range(MHz)	Test Mode	Frequency (MHz)	L1-L0 (SPL)	Result
0.15 ~ 10	AC means Power port	2.56	-31	A
10 ~ 30		18.35	-33	A
30 ~ 80		73.57	-34	A
0.15 ~ 10	Analogue/digital data ports	8.15	-32	A
10 ~ 30		25.09	-35	A
30 ~ 80		47.21	-31	A

Test engineer: Nunny

13. Power Frequency Magnetic Field Immunity Test

13.1. Test Setup

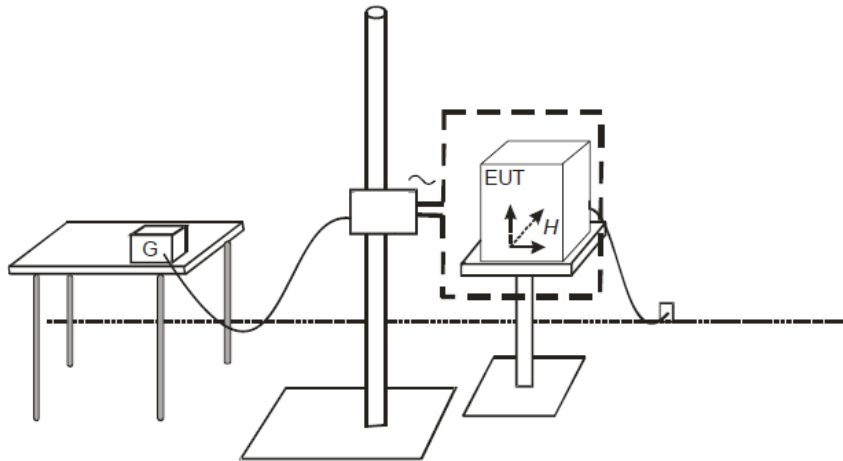

13.2. Test Severity Levels

Level	Magnetic field strength (A/m)
1	1
2	3
3	10
4	30
5	100
X ¹⁾	special
NOTE 1 "X" is an open level. This level can be given in the product specification.	



13.3. Test Result and Data

Final Test Result : **PASS**
 Required performance criteria : A
 Basic Standard : IEC 61000-4-8
 Product Standard : EN 55035
 Model No. : AGP277QKDC
 Temperature : 24°C
 Relative Humidity : 50%
 Atmospheric Pressure : 1010hPa
 Test Date : 2025.11.10
 Test Mode 1 : Full system (HDMI1 mode 2560*1440@540Hz +USB-B:KVM) Signal from PC with +USB*3 to U Disk+USB-C to Load(20V/3.25A)+Built-in speaker For 230V(Horizontal)
 Test Mode 13 : Full system (HDMI1 mode 2560*1440@540Hz +USB-B:KVM) Signal from PC with +USB*3 to U Disk+USB-C to Load(20V/3.25A)+Built-in speaker For 110V(Horizontal)

Power Frequency Magnetic Field : <u>50/60</u> Hz, <u>1</u> A/m		
Coil Orientation	Testing duration	Results
X-axis	1.0 Min	A
Y-axis	1.0 Min	A
Z-axis	1.0 Min	A

Note: "A" Mean the EUT function is normal working during the test.

Test engineer: Nunny



14. Voltage Dips and Voltage Interruptions Immunity Test Setup

14.1. Test Conditions

1. Source voltage and frequency: AC 230V / 50 Hz, 110V / 60 Hz, Single phase.
2. Test of interval: 10 sec.
3. Level and duration: Sequence of 3 dips/interrupts.
4. Voltage rise (and fall) time: 1 ~ 5 μ s.
5. Test severity:

Voltage dips and Interrupt reduction (%)	Test Duration (period)	Required performance criteria
>95%	250	C
30%	25	C
>95%	0.5	B

14.2. TEST SETUP

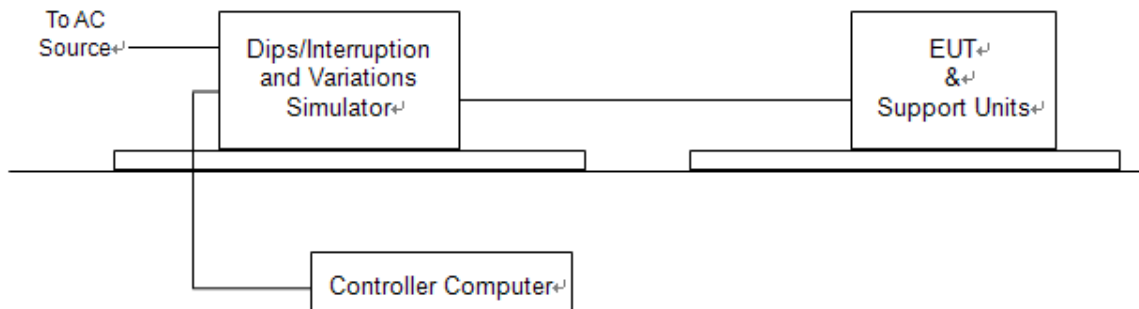

For the actual test configuration, please refer to the related item – Photographs of the Test Configuration.



14.3. Test Result and Data

Final Test Result : **PASS**
 Voltage dips:
 (B)Residual voltage<5% 0.5period
 Required performance : (C) Residual voltage 70% 25period(50Hz),30period(60Hz)
 Criteria : Voltage interruptions:
 (C)Residual voltage <5% 250period(50Hz),300period(60Hz)
 Basic Standard : IEC 61000-4-11
 Product Standard : EN 55035
 Model No. : AGP277QKDC
 Temperature : 24 °C
 Relative Humidity : 50%
 Atmospheric Pressure : 1010hPa
 Test Date : 2025.11.10
 Test Mode 1 : Full system (HDMI1 mode 2560*1440@540Hz +USB-B:KVM)
 : Signal from PC with +USB*3 to U Disk+USB-C to
 Load(20V/3.25A)+Built-in speaker For 230V(Horizontal)
 Test Mode 13 : Full system (HDMI1 mode 2560*1440@540Hz +USB-B:KVM)
 : Signal from PC with +USB*3 to U Disk+USB-C to
 Load(20V/3.25A)+Built-in speaker For 110V(Horizontal)

Voltage(UT): AC <u>230</u> V <u>50</u> Hz Interval(s) : <u>10s</u> Times : <u>3</u>				
Test mode	Test level UT %	Durations (period)	Phase / Result	
			0°	180°
Voltage interruptions	>95%	250	B	B
Voltage dips	30%	25	A	A
	>95%	0.5	A	A

Voltage(UT): AC <u>110</u> V <u>60</u> Hz Interval(s) : <u>10s</u> Times : <u>3</u>				
Test mode	Test level UT %	Durations (period)	Phase / Result	
			0°	180°
Voltage interruptions	>95%	300	B	B
Voltage dips	30%	30	A	A
	>95%	0.5	A	A

Note: "A" means the EUT function is normal working during the test.
 "B" means the EUT function is affected during the test, and it can be recovered by auto resetting.
 "C" means the EUT function is affected during the test, and it can be recovered by manual resetting.

Test engineer: Nunny



15. Photographs of the test configuration

Conducted Emission for AC main power Test

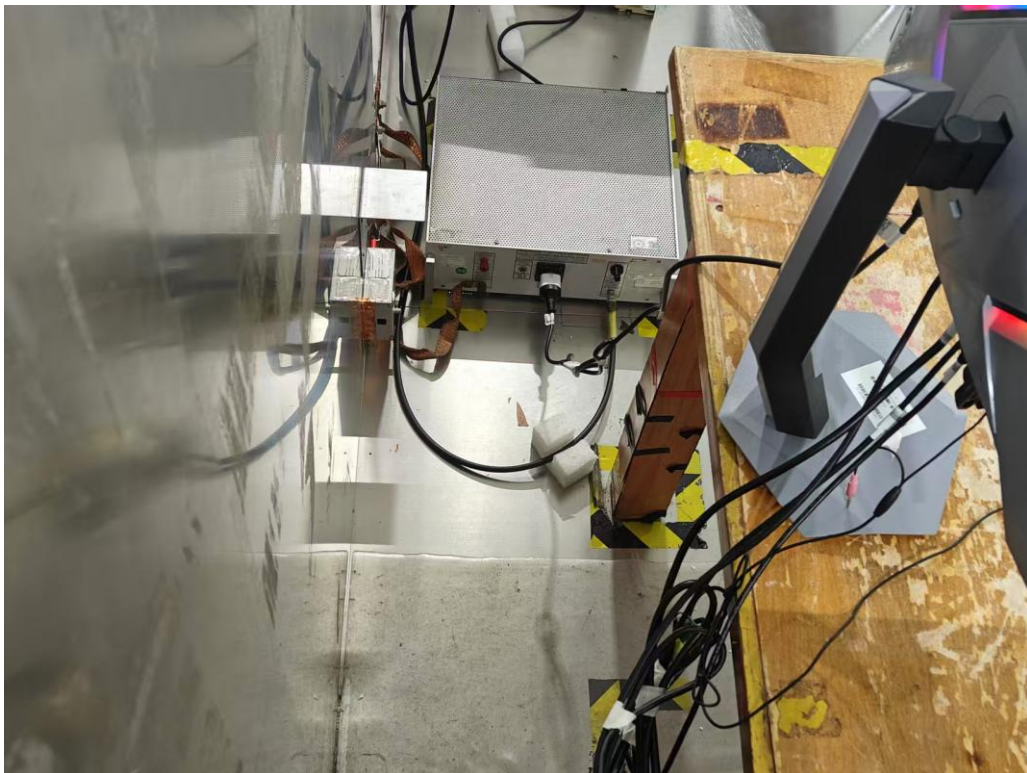
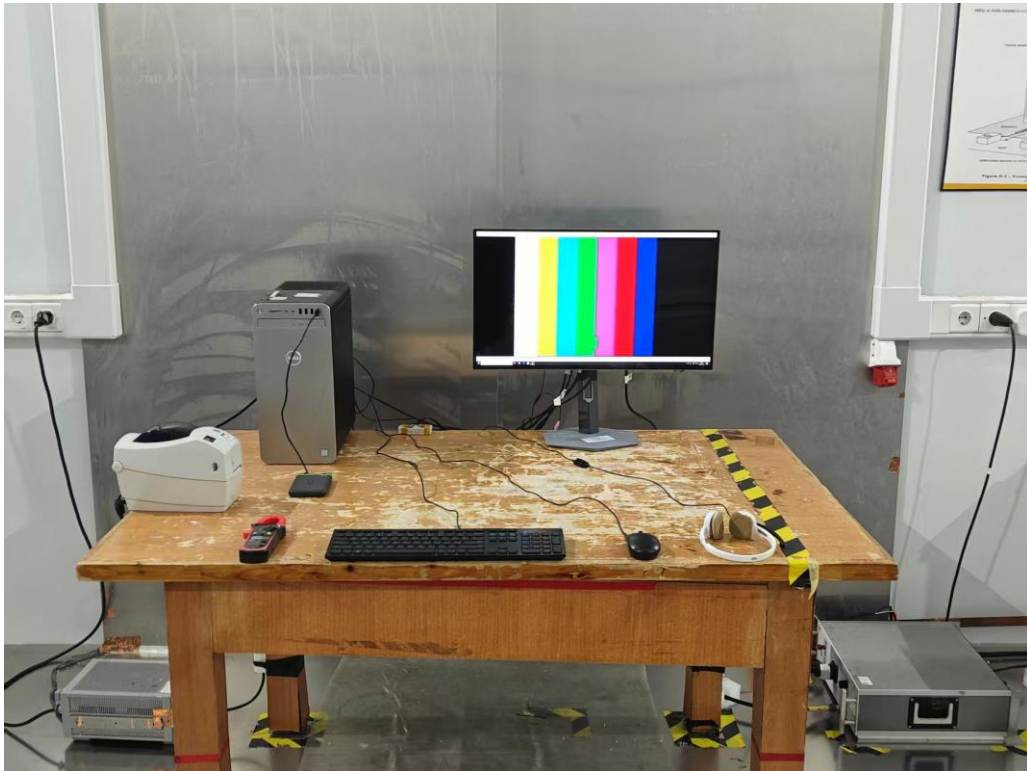



Radiated Emission Test (30MHz~1GHz)

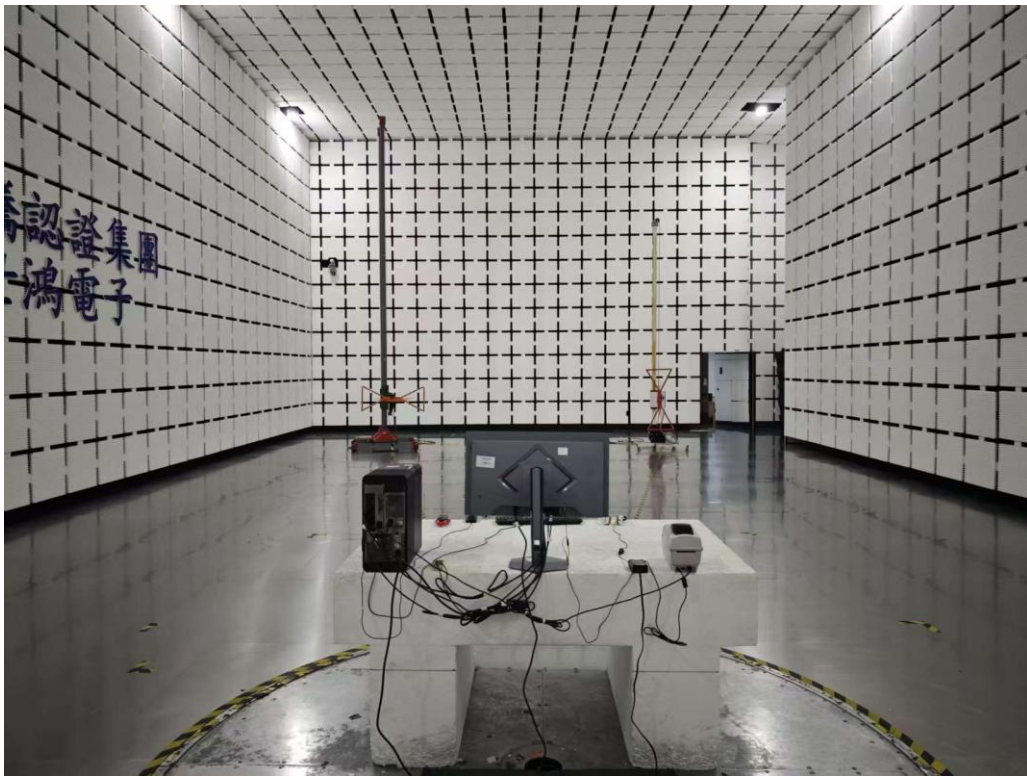
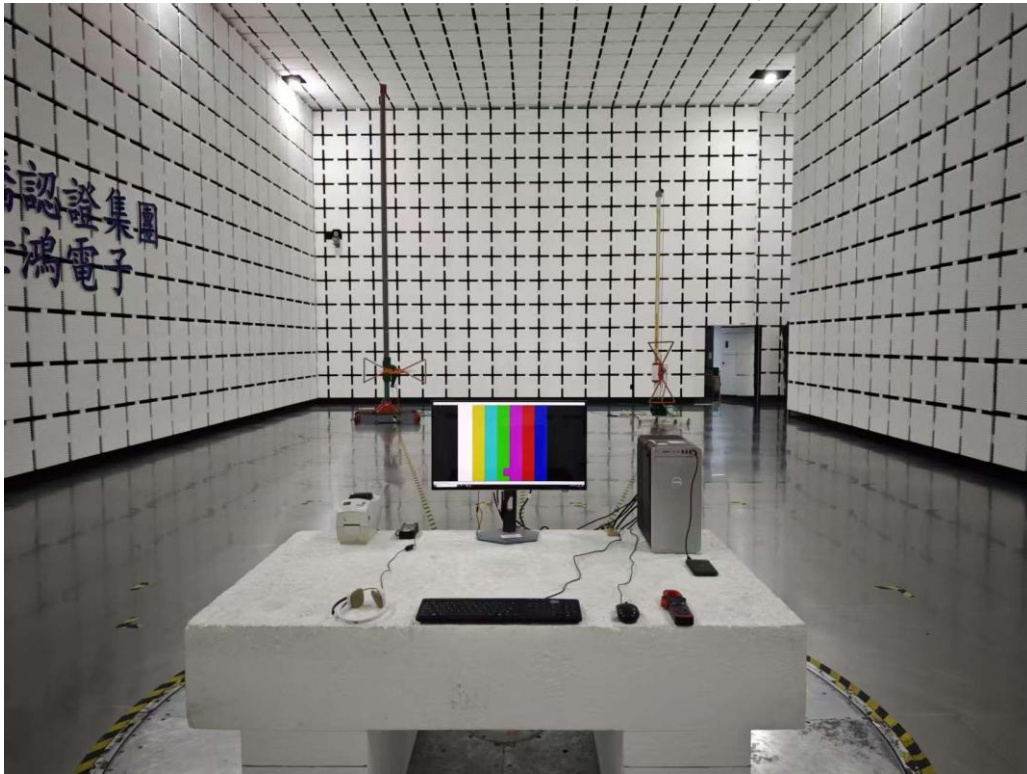



Radiated Emission Test (1GHz~6GHz)

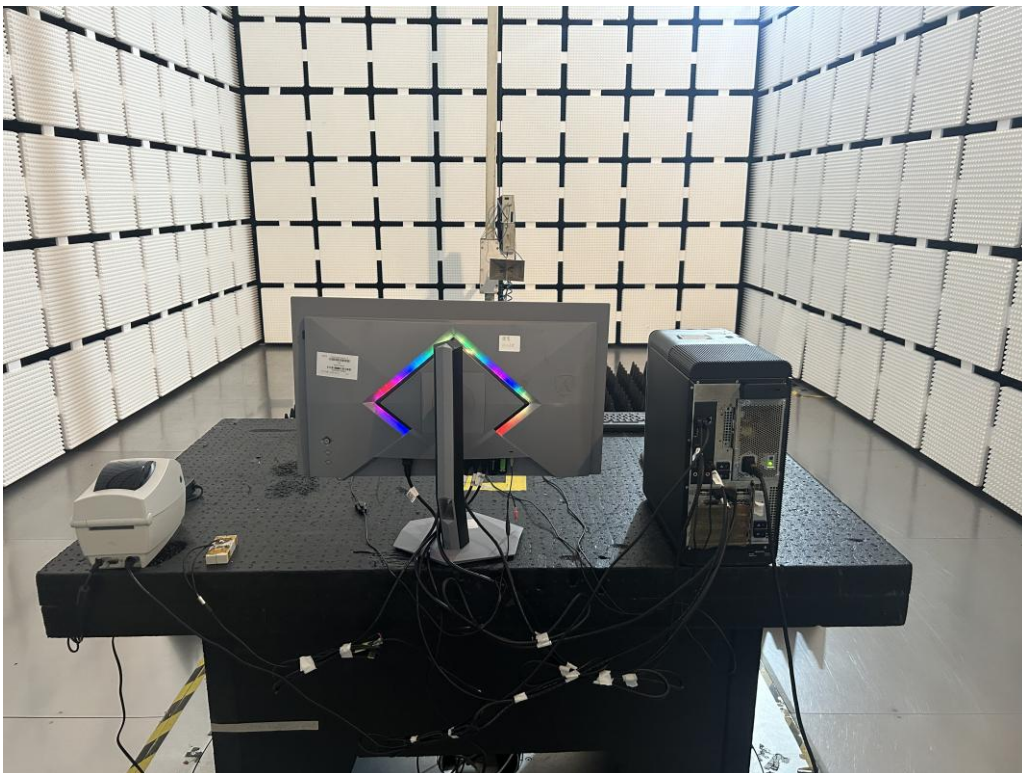
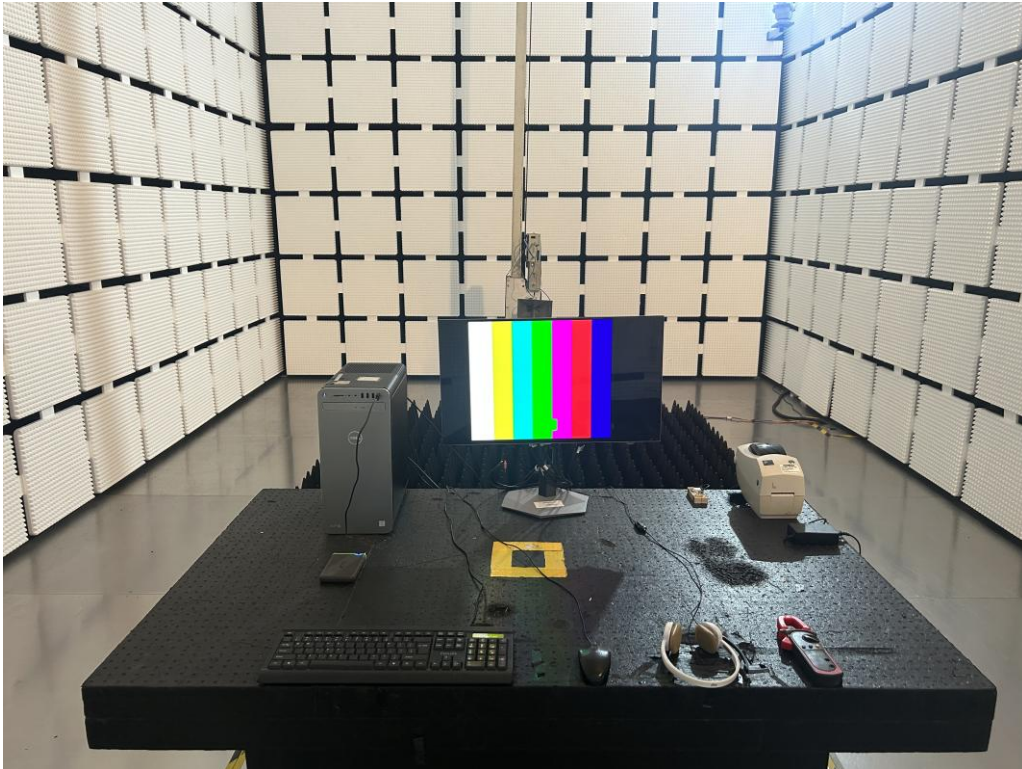



Harmonics & Voltage Fluctuations



ESD Test





Surge Test

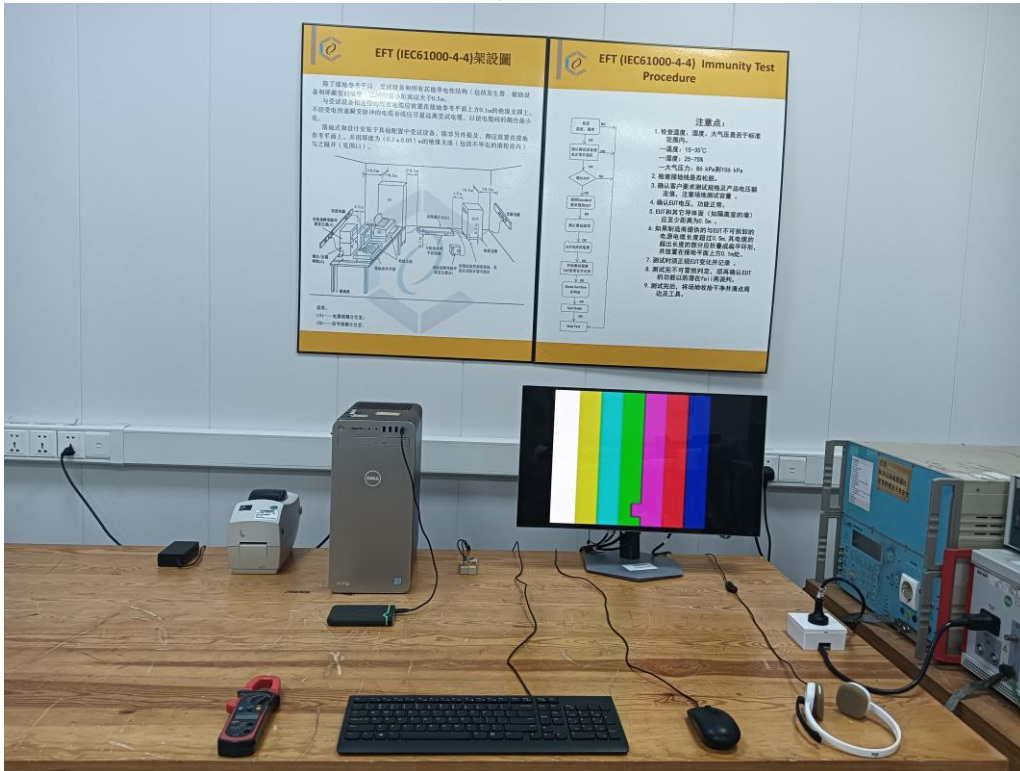

CS Test for power port

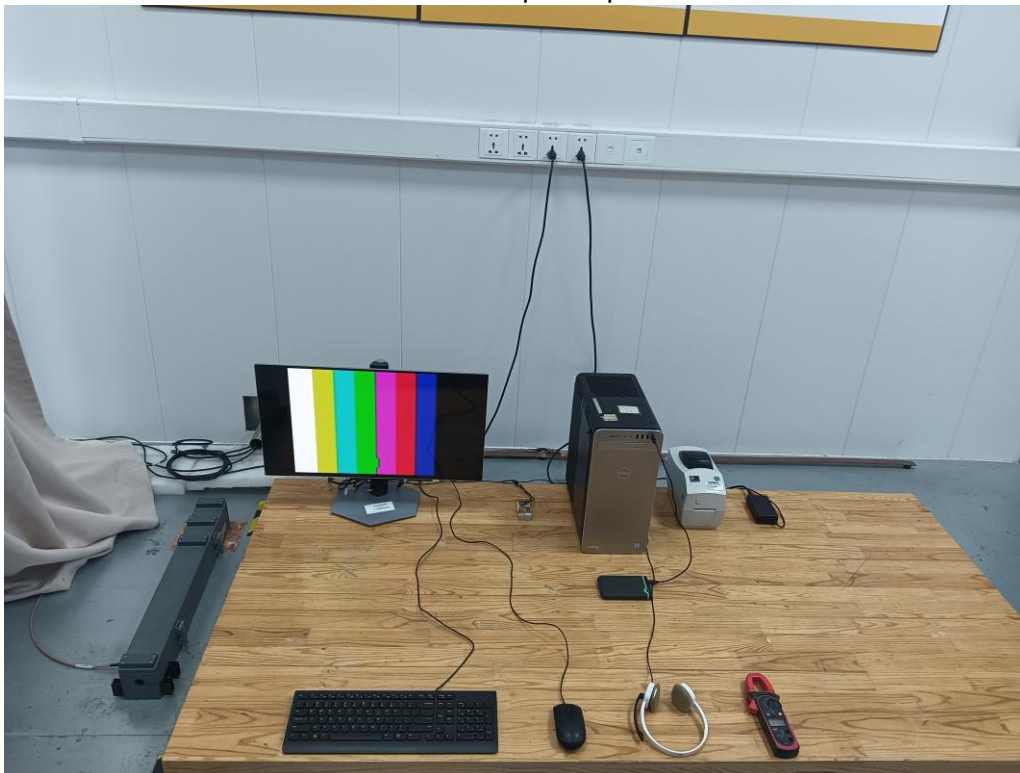



PFM Test

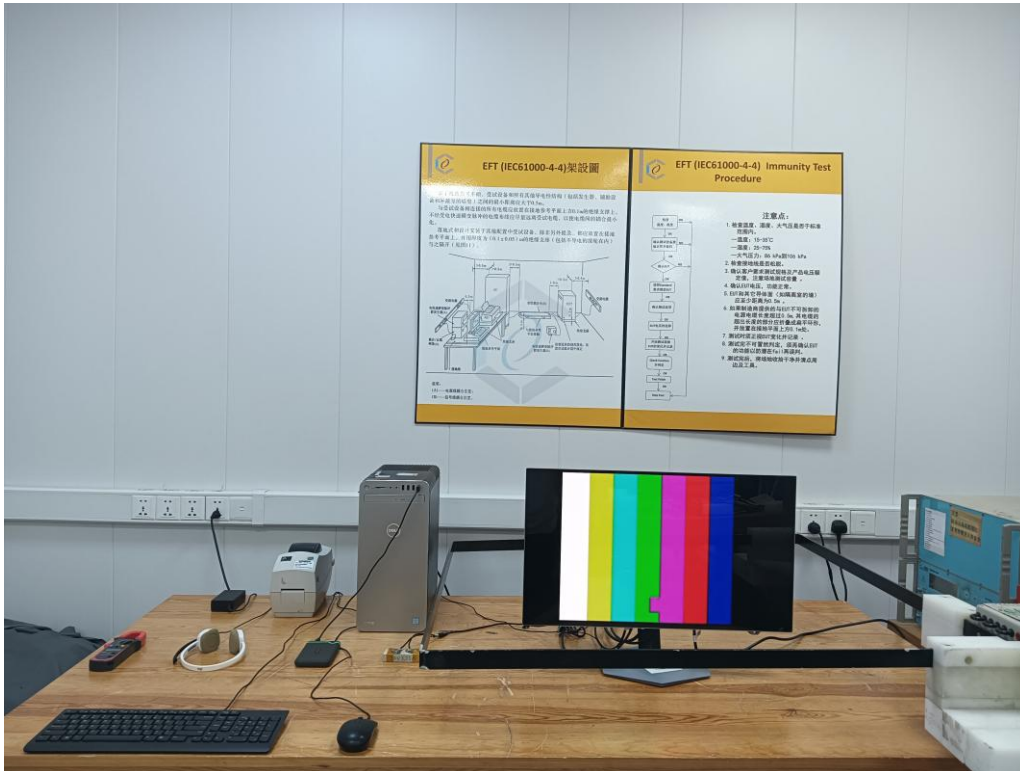

Dips Test



**16. List of Measuring Equipment**

Conducted Emission					
Instrument/Ancillary	Manufacturer	Model No.	Serial No.	Calibration	Valid Date.
Test Receiver	R&S	ESCI	100564	2024/12/30	2025/12/29
LISN	SCHWARZBECK	NSLK 8127	8127748	2024/12/30	2025/12/29
LISN	R&S	ENV216	100024	2024/12/30	2025/12/29
Pulse Limiter with 10dB Attenuation	SCHWARZBECK	VTSD 9561-F	9561-F106	2024/12/30	2025/12/29
Cable	Aoda	RG214	Cable-06	2024/12/30	2025/12/29
Temperature/Humidity Meter	GEMLEAD	STH200A	N/A	2025/07/25	2026/07/24
Software	AUDIX	E3	Version: 8.14806b	N/A	N/A
Test Site	Yiheng	AC-DG-005	N/A	2023/05/06	2026/05/05

Radiated Emission below 1GHz					
Instrument/Ancillary	Manufacturer	Model No.	Serial No.	Calibration Date	Valid Date
Vertical					
EMI Test Receiver	R&S	ESCI	100565	2025/07/23	2026/07/22
Preamplifier	Mini-Circuits	ZKL-2+	S1773911904	2025/07/23	2026/07/22
Bilog Antenna	Sunol Science	JB1	A072414-2	2024/06/12	2026/06/11
Cable	CH-CoDesigh	CCXA81-SMAM NM-9M	21070881	2025/07/23	2026/07/22
Cable	CH-CoDesigh	CCXA81-SMAM NM-7M-L	21070884	2025/07/23	2026/07/22
Horizontal					
EMI Test Receiver	R&S	ESCI7	100968	2024/12/30	2025/12/29
Preamplifier	EMCI	EMCI 030-00-3230	SN016723	2024/12/30	2025/12/29
Bilog Antenna	Sunol Science	JB6	A111218	2025/01/16	2027/01/15
Cable	CH-CoDesigh	CCXA81-SMAM NM-9M	21070878	2024/12/30	2025/12/29
Cable	CH-CoDesigh	CCXA81-SMAM NM-10M-L	21070887	2024/12/30	2025/12/29
Temperature/Humidity Meter	GEMLEAD	STH200A	N/A	2025/07/25	2026/07/24
Software	AUDIX	E3	Version: 8.14806b	N/A	N/A
Test Site	Yiheng	AC-DG-007	N/A	2024/04/12	2027/04/11



Radiated Emission Above 1GHz					
Instrument/Ancillary	Manufacturer	Model No.	Serial No.	Calibration Date	Valid Date
Preamplifier	COM-MW	DPA8-1000-1800 0-1012	06253337	2025/06/30	2026/06/29
Broad-Band Horn Antenna	Schwarzbeck	BBHA9120D	9120D-619	2024/01/03	2026/01/02
FSQ Signal Analyzer	R&S	FSQ40	200012	2024/12/31	2025/12/30
Cable	Jiuzhoubona	T-SMA	SMA48AL-7 000	2024/12/30	2025/12/29
Cable	CH-CoDesigh	CCXA81-SMAM NM-1M	Cable-05	2024/12/30	2025/12/29
Temperature/ Humidity Meter	GEMLEAD	STH200A	N/A	2025/07/25	2026/07/24
Software	AUDIX	E3	Version: 8.14806b	N/A	N/A
Test Site	Yiheng	AC-DG-001	N/A	2023/05/08	2026/05/07

Harmonic and Flicker Emissions					
Instrument	Manufacturer	Model No.	Serial No.	Calibration Date	Valid Date
Power Source	TESEQ	NSG 1007-3	1330A03972	2025/07/22	2026/07/21
Harmonic & Flicker Tester	TESEQ	CCN 1000-1	1330A03972	2025/07/22	2026/07/21
Software	TESEQ	CTS4	4.29.00	N/A	N/A
Temperature/ Humidity Meter	mingle	ETH529	N/A	2025/01/02	2026/01/01
Test Site	Yiheng	AC-DG-002	N/A	2023/05/06	2026/05/05

ESD					
Instrument	Manufacturer	Model No.	Serial No.	Calibration Date	Valid Date
ESD Simulator	TESEQ	NSG437	575	2025/07/22	2026/07/21
Temperature/ Humidity Meter	mingle	ETH529	N/A	2025/01/02	2026/01/01



RS					
Instrument	Manufacturer	Model No.	Serial No.	Calibration Date	Valid Date
Signal Generator	R&S	SML03	103287	2025/07/22	2026/07/21
Signal Generator	R&S	SMR30	100049	2025/07/22	2026/07/21
Power Sensor	R&S	NRP-Z11	106374	2025/01/02	2026/01/01
Power Amplifier	BONN	BLWA0830-160 /100/40D	76659	2025/07/22	2026/07/21
Preamplifier	MILMEGA	AS1860-30	10040456	2025/07/22	2026/07/21
Electric field probe	NARDA	EP601	811ZX30896	2025/01/02	2026/01/01
EMS Antenna	R&S	HL046E	100028	N/A	N/A
Broad-Band Horn Antenna	Schwarzbeck	BBHA9120 E	475	2025/01/12	2027/01/11
Software	AUDIX	I2	5.0.0.0	N/A	N/A
Temperature/ Humidity Meter	mingle	ETH529	N/A	2025/01/02	2026/01/01
Audio analyzer	R&S	UPV	103170	2024/12/30	2025/12/29
Low Noise Microphone	Bruel&Kj	4955	3094785	2025/01/02	2026/01/01
Microphone Conditioning Amplifier	Bruel&Kj	2690-0F2	3008833	2025/01/02	2026/01/01
Sound Calibrator	Bruel&Kj	4231	3020682	2025/01/02	2026/01/01
Test Site	Yiheng	AC-DG-006	N/A	2023/05/09	2026/05/08

EFT; SURGE; PFMF; DIPS					
Instrument	Manufacturer	Model No.	Serial No.	Calibration Date	Valid Date
Integrated Generator	TESEQ	NSG 3040	2032	2025/07/22	2026/07/21
voltage regulator	TESEQ	VAR 3005-S16	850	2025/07/22	2026/07/21
TRANSIENT	EMCPARTNER	TRA2000IN6	901	2025/07/22	2026/07/21
Coupling clamp	EMCPARTNER	CN-EFT1000	547	2025/07/22	2026/07/21
H-Filed-Loop	EMCPARTNER	MF1000-1	144	2025/07/23	2026/07/22
CDN	EMTEST	CNV508T5	P 1546167499	2025/07/22	2026/07/21
Temperature/ Humidity Meter	mingle	ETH529	N/A	2025/01/02	2026/01/01
Test Site	Yiheng	AC-DG-002	N/A	2023/05/06	2026/05/05



CS					
Instrument	Manufacturer	Model No.	Serial No.	Calibration Date	Valid Date
Conducted immunity test system	TESEQ	NSG 4070	35902	2025/07/22	2026/07/21
EM Injection clamp	TESEQ	KEMZ 801A	33492	2025/07/22	2026/07/21
CDN	TESEQ	CDN M016	35841	2025/07/22	2026/07/21
6 dB Attenuator	TESEQ	ANT 6050	34864	2025/07/22	2026/07/21
Software	SKET	EMS-C	1.2.0.42	N/A	N/A
Temperature/ Humidity Meter	mingle	ETH529	N/A	2025/01/02	2026/01/01
Audio analyzer	R&S	UPV	103170	2024/12/30	2025/12/29
Low Noise Microphone	Bruel&Kj	4955	3094785	2025/01/02	2026/01/01
Microphone Conditioning Amplifier	Bruel&Kj	2690-0F2	3008833	2025/01/02	2026/01/01
Sound Calibrator	Bruel&Kj	4231	3020682	2025/01/02	2026/01/01
Test Site	Yiheng	AC-DG-002	N/A	2023/05/06	2026/05/05

----- End of the report -----